

<b>MANNESMANN REXROTH</b>	<b>Variable displacement pump A4VSO</b>		<b>RE 92050/09.97</b>
	series 1, 2 and 3 open circuit axial piston, swashplate design		
Brueninghaus Hydromatik	Sizes 40...1000	Nominal pressure 350 bar	Peak pressure 400 bar

**High pressure range****A4VSO**

For separate descriptions of the control devices see RE data sheets

RE 92055, RE 92060, RE 92064,  
RE 92072, RE 92076, RE 92080

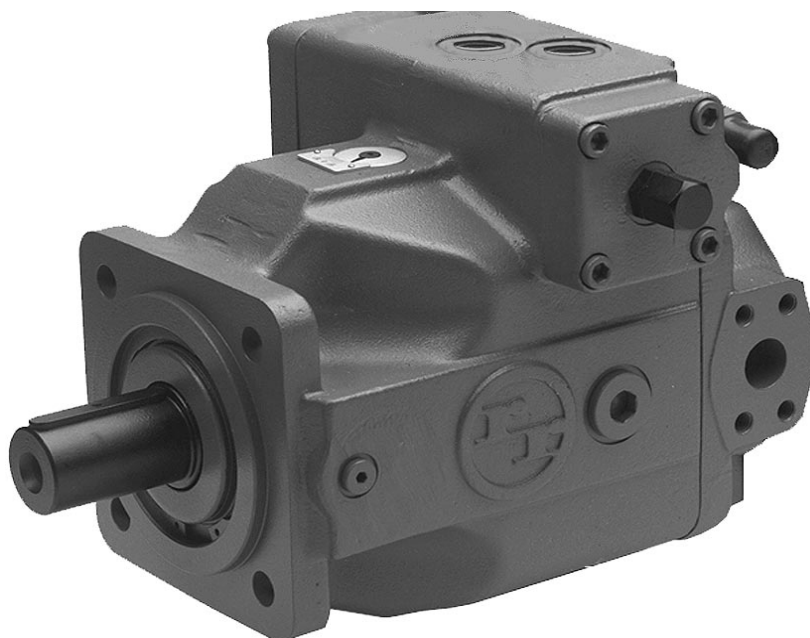

The variable displacement axial piston pump type A4VSO in swashplate design is designed for open circuit hydrostatic drives.

The flow is proportional to the input drive speed and displacement. By adjusting the swashplate it is possible to infinitely vary the flow.

- Slot-controlled swashplate design
- Infinitely variable displacement
- Good suction characteristics
- Permissible nominal operating pressure 350 bar
- Low noise level
- Long service life
- Drive shaft capable of absorbing axial and radial loads
- Good power/weight ratio
- Modular design
- Short control times
- Through drive and pump combinations possible
- Swash plate angle indicator
- Optional mounting position
- Operation on HF fluids under reduced operational parameters possible

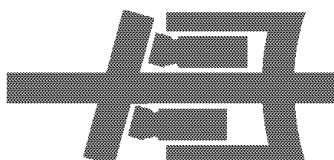
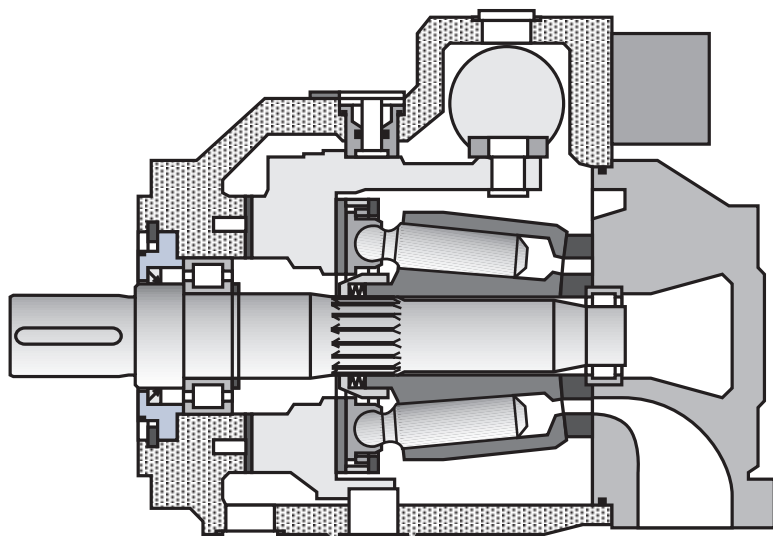

Variable displacement pump A4VSO, series 1, 2 and 3

### Ordering details

#### Hydraulic fluid / version

	40	71	125	180	250	355	500	750	1000	
Mineral oil (no code)	●	●	●	●	●	●	●	●	●	
HF hydraulic fluid (with the exception of Skydrol)	●	●	●	●	●	●	●	-	-	E
High-Speed-Version	-	-	-	-	●	●	●	-	-	H

#### Axial piston unit

Swashplate design, variable, for industrial applications	<b>A4VS</b>
--	-------------

#### Boost pump (Impeller)

	40	71	125	180	250	355	500	750	1000	
Without boost pump (no code)	●	●	●	●	●	●	●	●	●	
With boost pump (Impeller) only for version 25	-	-	-	-	-	-	-	●	-	L

#### Type of operation

Pump, open circuit	<b>O</b>
--------------------	----------

#### Nominal size

≥ displacement $V_{g,max}$ (cm <sup>3</sup> )	<b>40</b>	<b>71</b>	<b>125</b>	<b>180</b>	<b>250</b>	<b>355</b>	<b>500</b>	<b>750</b>	<b>1000</b>
---	-----------	-----------	------------	------------	------------	------------	------------	------------	-------------

#### Control device

	DR	FR	LR	MA	EM	HW	HM	HS	EO	HD	DS		
Pressure control	●	●	●	●	●	●	●	●	●	●	●	DR..	} see <b>RE 92060</b>
Flow control	●	●	●	●	●	●	●	-	-	-	-	FR..	
Power control with hyperbolic curve	●	●	●	●	●	●	●	●	○	○	○	LR..	} see <b>RE 92072</b>
Manual control	●	●	●	●	●	●	●	●	-	-	-	MA..	
Electric motor control	●	●	●	●	●	●	●	●	-	-	-	EM..	} see <b>RE 92076</b>
Hydraulic control, position dependent	●	●	●	●	●	●	●	●	○	○	○	HW..	
Hydraulic control, volume dependent	●	●	●	●	●	●	●	●	○	○	○	HM..	} see <b>RE 92055</b>
Hydraulic control with servo/proportional valve	●	●	●	●	●	●	●	●	○	○	○	HS..	
Electronic control	●	●	●	●	●	●	●	●	○	○	○	EO..	
Hydraulic control, pressure dependent	●	●	●	●	●	●	●	●	○	○	○	HD..	
Speed control, secondary controlled	●	●	●	●	●	●	●	●	○	○	○	DS..	

#### Series

	●	●	-	-	-	-	-	-	-	-	-	<b>10</b>
	-	-	●	●	-	●	-	-	-	-	-	<b>22</b>
	-	-	○	○	●	○	●	●	●	●	●	<b>30</b>

#### Direction of rotation

Viewed on shaft end	clockwise	<b>R</b>
	anti-clockwise	<b>L</b>

#### Seals

NBR (Nitrile rubber to DIN ISO 1629) with shaft seal FPM	<b>P</b>
FPM (Fluorine india rubber to DIN ISO 1629)	<b>V</b>

#### Shaft end

Keyed parallel shaft DIN 6885	<b>P</b>
Splined shaft DIN 5480	<b>Z</b>

#### Mounting flange

	40	71	125	180	250	355	500	750	1000	
ISO 4-hole	●	●	●	●	●	●	-	-	-	<b>B</b>
ISO 8-hole	-	-	-	-	-	-	●	●	●	<b>H</b>

- = available
- = in preparation
- = not available

**■** = preferred programme (with short delivery times)  
(for preferred types see page 39)

Variable displacement pump A4VSO, series 1, 2 and 3

	A4VS		O		/		-						
Hydraulic fluid / version													
Axial piston unit													
Boost pump													
Type of operation													
Nominal size													
Control device													
Series													
Direction of rotation													
Seals													
Shaft end													
Mounting flange													

<b>Service line connection</b>	<b>40</b>	<b>71</b>	<b>125</b>	<b>180</b>	<b>250</b>	<b>355</b>	<b>500</b>	<b>750</b>	<b>1000</b>		
Connections B and S: SAE on side 90° offset, metric fixing screws	●	●	●	●	●	●	●	●	●	-	13
Connections B and S: SAE on side 90° offset, metric fixing screws 2nd pressure connection B, opposite B - when delivered blanked off with a flange	●	●	●	●	●	●	●	●	●		25

<b>Through drive</b>			●	●	●	●	●	●	●	●	●	●	●	●	●	●	N00
Without auxiliary pump, without through drive																	
With through drive to accept an axial piston unit, gear or radial piston pump																	
Flange	Hub/shaft	to accept															
ISO 125, 4-hole	Splined shaft 32x2x30x14x9g	A4VSO/H/G 40	●	●	●	●	●	●	●	○	○						K31
ISO 140, 4-hole	Splined shaft 40x2x30x18x9g	A4VSO/H/G 71	-	●	●	●	●	●	●	○	○						K33
ISO 160, 4-hole	Splined shaft 50x2x30x24x9g	A4VSO/H/G 125	-	-	●	●	●	●	●	○	○						K34
ISO 160, 4-hole	Splined shaft 50x2x30x24x9g	A4VSO/G 180	-	-	-	●	●	●	●	○	○						K34
ISO 224, 4-hole	Splined shaft 60x2x30x28x9g	A4VSO/H/G 250	-	-	-	-	●	●	●	○	○						K35
ISO 224, 4-hole	Splined shaft 70x3x30x22x9g	A4VSO/G 355	-	-	-	-	-	●	●	○	○						K77
ISO 315, 8-hole	Splined shaft 80x3x30x25x9g	A4VSO/G 500	-	-	-	-	-	-	●	●	○						K43
ISO 400, 8-hole	Splined shaft 90x3x30x28x9g	A4VSO/G 750	-	-	-	-	-	-	-	●	○						K76
ISO 400, 8-hole	Splined shaft 100x3x30x32x9g	A4VSO/G 1000	-	-	-	-	-	-	-	-	●						K88
ISO 80, 2-hole	Splined shaft 3/4" 19-4 (SAE A-B)	A10VSO 18	○	○	●	○	○	○	○	○	○						KB2
ISO 100, 2-hole	Splined shaft 7/8" 22-4 (SAE B)	A10VSO 28	●	○	○	○	○	○	○	○	○						KB3
ISO 100, 2-hole	Splined shaft 1" 25-4 (SAE B-B)	A10VSO 45	○	○	○	○	●	○	○	○	○						KB4
ISO 125, 2-hole	Splined shaft 1 1/4" 32-4 (SAE C)	A10VSO 71	-	○	●	●	○	○	○	○	○						KB5
ISO 125, 2-hole	Splined shaft 1 1/2" 38-4 (SAE C-C)	A10VSO 100	-	-	○	○	○	○	○	○	○						KB6
ISO 180, 4-hole	Splined shaft 1 3/4" 44-4 (SAE D)	A10VSO 140	-	-	-	○	●	●	○	○	○						KB7
82-2 (SAE A, 2-hole)	Splined shaft 5/8" 16-4 (SAE A)	G2 / GC2/GC3-1X	●	●	●	●	●	●	●	●	○						K01
82-2 (SAE A, 2-hole)	Splined shaft 3/4" 19-4 (SAE A-B)	A10VSO 18	●	●	●	●	●	●	●	○	○						K52
101-2 (SAE B, 2-hole)	Splined shaft 7/8" (SAE B)	G3	●	●	●	●	●	●	●	○	○						K02
101-2 (SAE B)	Splined shaft 25-4 (SAE B-B)	GC4-1X, A10VO 45	○	○	○	○	○	○	○	○	○						K04
127-2 (SAE C)	Splined shaft 32-4 (SAE C)	A10VO 71	-	○	○	○	○	○	○	○	○						K07
101-2 (SAE B)	Splined shaft 32-4 (SAE C)	GC5-1X	○	●	●	○	○	○	○	○	○						K06
127-2 (SAE C)	Splined shaft 38-4 (SAE C-C)	GC6-1X, A10VO 100	-	-	●	●	●	○	○	○	○						K24
152-4 (SAE D)	Splined shaft 44-4 (SAE D)	A10VO 140	-	-	-	○	○	○	○	○	○						K17
Ø 63, metric 4-hole	Keyed shaft Ø 25	R4	●	●	●	○	●	○	○	○	○						K57
101-2 (SAE B)	Splined shaft 22-4(SAE B)	G4, A10VO 28	●	●	●	●	●	○	●	○	○						K68
With through drive shaft, without hub, without adapter flange, with cover plate			●	●	●	●	●	●	○	○							K99

<b>Filtration (only with HS and DS control)</b>	
Without filter	N
Sandwich plate filter (with HS and DS control see RE 92076 and RE 92055)	Z

**Combination pumps**

- If a **second Brueninghaus pump is to be fitted in the factory**, then both type codes should be joined with "+".  
Type code 1st pump + type code 2nd pump  
**Ordering example:** A4VSO 125 DR/22R – PPB13K33 + A4VSO 71 DR/10R – PZB13N00.
- If a **gear or radial piston pump is to be fitted in the factory**, please consult us.

## Hydraulic fluid

For extensive information on the selection of hydraulic fluids and for application conditions, please consult our data sheet RE 90220 (mineral oils), RE 90221 (ecologically acceptable pressure fluids) and RE 90223 (HF pressure fluids). When operating with ecologically acceptable and HF fluids limitations to the technical data may be necessary.

### Operating viscosity range

In order to obtain optimum efficiency and service life, we recommend that the operating viscosity (at operating temperature) be selected in the range

$$v_{opt} = \text{optimum operating viscosity } 16...36 \text{ mm}^2/\text{s}$$

referred to tank temperature (open circuit).

### Limit of viscosity range

For critical operating conditions the following values apply:

$$v_{min} = 10 \text{ mm}^2/\text{s}$$

for short periods at max. permissible leakage oil temperature 90° C.

$$v_{max} = 1000 \text{ mm}^2/\text{s}$$

for short periods on cold start.

### Comments on the selection of the hydraulic fluid

In order to select the correct fluid, it is necessary to know the operating temperature in the tank (open circuit), in relation to the ambient temperature.

The hydraulic fluid should be selected such that, within the operating temperature range, the operating viscosity lies within the optimum range ( $v_{opt}$ ), see shaded section of selection diagram. We recommend that the higher viscosity grade is selected in each case.

### Selection diagram

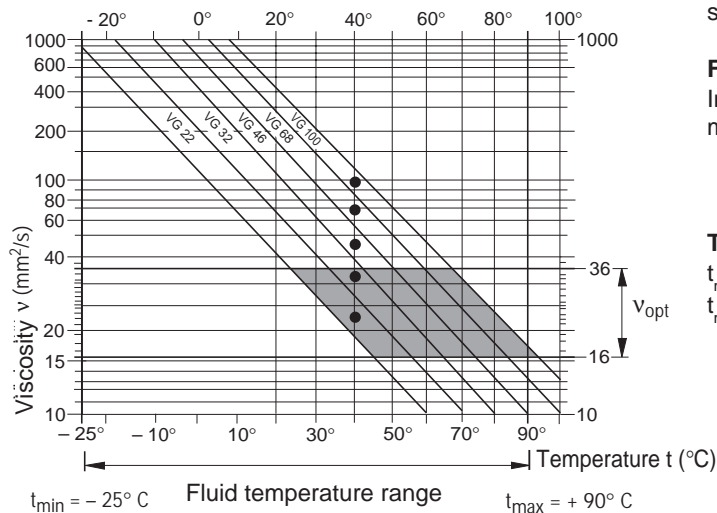

### Determination of displacement

Flow  $q_v = \frac{V_g \cdot n \cdot \eta_v}{1000}$  [L/min]

Drive torque  $T = \frac{1,59 \cdot V_g \cdot \Delta p}{100 \cdot \eta_{mh}}$  [Nm]

Drive power  $P = \frac{2\pi \cdot T \cdot n}{60000} = \frac{T \cdot n}{9549} = \frac{q_v \cdot \Delta p}{600 \cdot \eta_t}$  [kW]

Example: At an ambient temperature of X° C, the operating temperature in the tank is 60° C. Within the operating viscosity range ( $v_{opt}$ ; shaded area), this corresponds to viscosity range VG 46 or VG 68. VG 68 should be selected.

Important: The leakage oil (case drain oil) temperature is influenced by pressure and pump speed and is always higher than the tank temperature. However, at no point in the circuit may the temperature exceed 90° C.

### Bearing flushing

For the following operating conditions bearing flushing is required for safe continuous operation:

- Applications with special fluids (non-mineral oils), due to limited lubricity and narrow operating temperature range
- Operation at critical conditions of temperature and viscosity with mineral oil

Flushing is recommended with vertical mounting (drive shaft facing upwards), in order to ensure lubrication of the front bearing and shaft seal.

Flushing is carried out via port "U", which is located in the front flange area of the variable displacement pump. The flushing oil flows through the front bearing and leaves the system together with the pump leakage oil at the drain port.

The following flows are recommended for flushing:

Size	40	71	125	180	250	355	500	750	1000
Q <sub>Sp</sub> L/min	3	4	5	7	10	15	20	30	40

For the given flushing flows there will be a pressure difference of approx. 2 bar (series 1 and 2) and approx. 3 bar (series 3) between port "U" (including screwed fitting) and the leakage chamber.

### Notes regarding series 30

When using external bearing flushing at port U the throttle screw, which is to be found at port U, has to be screwed in up to its end stop.

### Filtration of the hydraulic fluid (axial piston unit)

In order to ensure correct functioning of the axial piston unit, a minimum level of cleanliness class

9 to NAS 1638

18/15 to ISO/DIS 4406 is required.

### Temperature range (see selection diagram)

$$t_{min} = -25^\circ \text{C}$$

$$t_{max} = +90^\circ \text{C}$$

Variable displacement pump A4VSO, series 1, 2 and 3

### Technical data

(valid for operation with mineral oil)

#### Operating pressure range - inlet side

Absolute pressure at port S (suction inlet)

$P_{abs\ min}$  \_\_\_\_\_ 0.8 bar  
 $P_{abs\ max}$  \_\_\_\_\_ 30 bar

#### Operating pressure range - outlet side

Pressure at port B

Nominal pressure  $p_N$  \_\_\_\_\_ 350 bar  
 Peak pressure  $p_{max}$  \_\_\_\_\_ 400 bar  
 (pressure data to DIN 24312)

Flow direction: S to B.

#### Determination of inlet pressure $p_{abs}$ at suction port S, or reduction of displacement when increasing drive speed

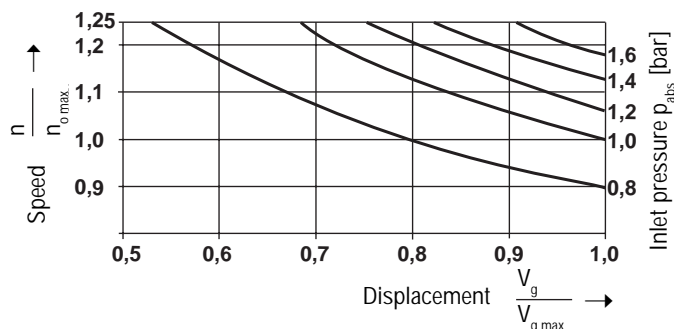

The inlet pressure is the static feed pressure or the minimum dynamic value of the boost pressure.

**Important:**  
 Max. permissible speed  $n_{o\ max\ perm.}$  (speed limit).

#### Case drain pressure

The permissible case drain pressure (housing pressure) is dependent on the drive speed (see diagram).

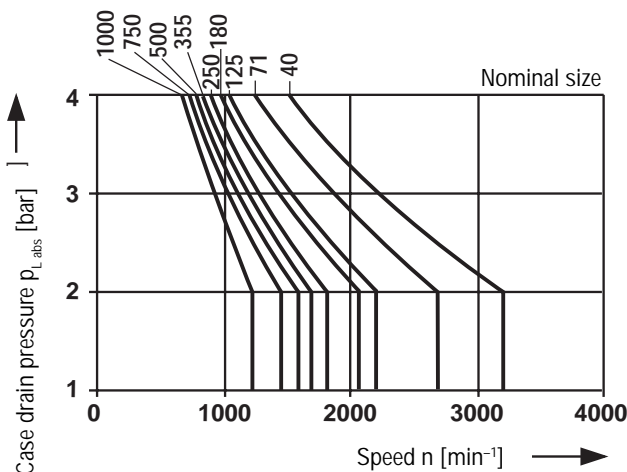

Max. case drain pressure (housing pressure)

$P_{L\ abs\ max}$  \_\_\_\_\_ 4 bar

These are approximate values. Under certain operating conditions a reduction in these values may be necessary.

**Table of values** (theoretical values, without considering  $\eta_{mh}$  and  $\eta_v$ ; values rounded off)

Nominal size		40	71	125	180	250/H*	355/H*	500/H*	750	750 with boost pump	1000	
Displacement	$V_{g\ max}$ cm <sup>3</sup>	40	71	125	180	250/250	355/355	500/500	750	750	1000	
Max. speed with inlet pressure $p_{abs}$ 1 bar at port S	$n_{o\ max}$ min <sup>-1</sup>	2600	2200	1800	1800	1500/1900	1500/1700	1320/1500	1200	1500	1000	
Max. permissible speed (speed limit) with increased inlet pressure $p_{abs}$ or reduced displacement $V_g < V_{g\ max}$	$n_{o\ max\ zul.}$ min <sup>-1</sup>	3200	2700	2200	2100	1800/2100	1700/1900	1600/1800	1500	1500	1200	
Max. flow	at $n_{o\ max}$	$q_{vo\ max}$ L/min	104	156	225	324	375/475	533/604	660/750	900	1125	1000
	at $n_E = 1500$ RPM	L/min	60	107	186	270	375	533	581 <sup>1)</sup>	770 <sup>1)</sup>	1125	-
Max. power ( $\Delta p = 350$ bar)	at $n_{o\ max}$	$P_{o\ max}$ kW	61	91	131	189	219/277	311/352	385/437	525	656	583
	at $n_E = 1500$ RPM	kW	35	62	109	158	219	311	339 <sup>1)</sup>	449 <sup>1)</sup>	656	-
Max. torque ( $\Delta p = 350$ bar)	at $V_{g\ max}$	$T_{max}$ Nm	223	395	696	1002	1391	1976	2783	4174	4174	5565
Torque ( $\Delta p = 100$ bar)	at $V_{g\ max}$	T Nm	64	113	199	286	398	564	795	1193	1193	1590
Moment of inertia about drive axis	J kgm <sup>2</sup>	0.0049	0.0121	0.03	0.055	0.0959	0.19	0.3325	0.66	0.66	1.20	
Case drain volume	L	2	2.5	5	4	10	8	14	19	22	27	
Approx. weight (pump with pressure control)	m kg	39	53	88	102	184	207	320	460	490	605	
Permissible axial force	$\pm F_{ax\ max}$ N	600	800	1000	1400	1800	2000	2000	2200	2200	2200	
Permissible radial force	$F_{q\ max}$ N	1000	1200	1600	2000	2000	2200	2500	3000	3000	3500	

<sup>1)</sup>  $V_g < V_{g\ max}$

H\* = High-Speed-Version

Application of force

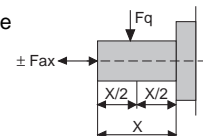

Variable displacement pump A4VSO, series 1, 2 and 3

### Input power and flow

(operating fluid: hydraulic oil ISO VG 46 DIN 51519, t = 50°C)

Overall efficiency: 
$$\eta_t = \frac{q_v \cdot p}{P_{qv \max} \cdot 600}$$

Volumetric efficiency: 
$$\eta_v = \frac{q_v}{q_{vtheor}}$$

#### Nominal size 40

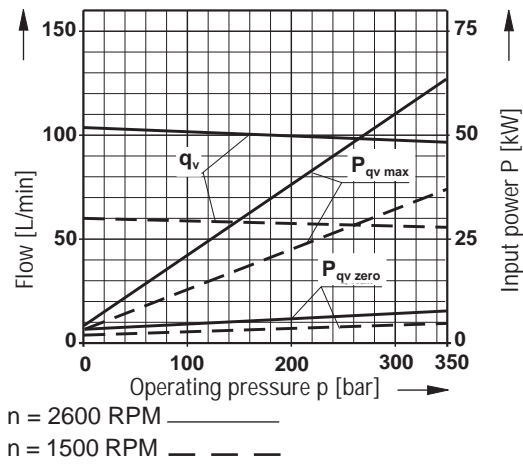

#### Nominal size 71

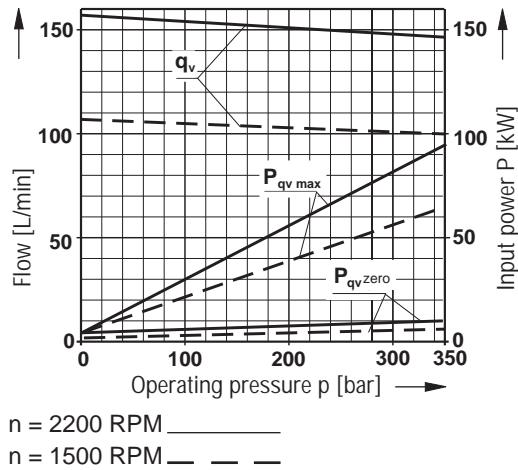

#### Nominal size 125

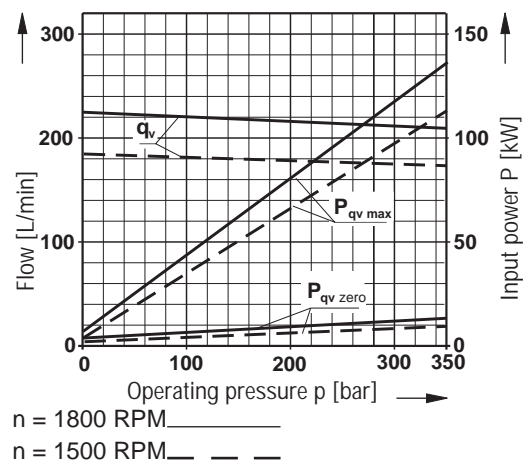

#### Nominal size 180

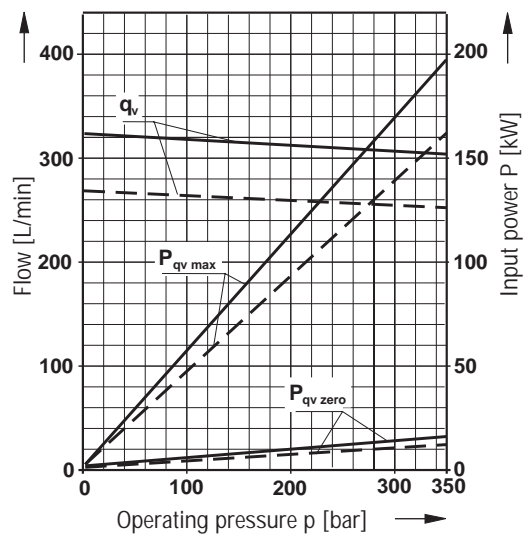

n = 1800 RPM \_\_\_\_\_  
n = 1500 RPM - - - - -

#### Nominal size 250

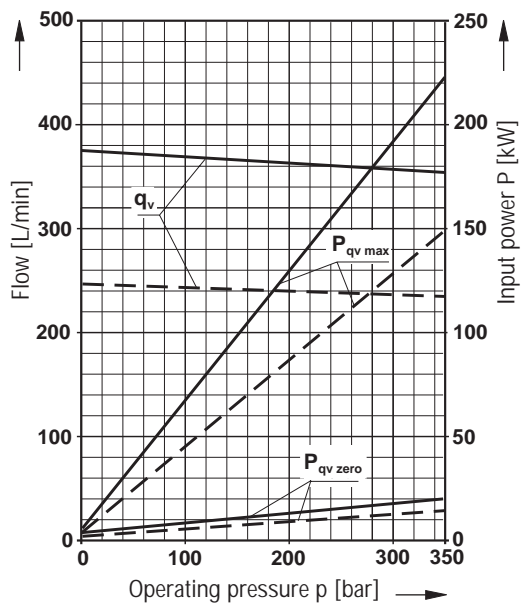

n = 1500 RPM \_\_\_\_\_  
n = 1000 RPM - - - - -

Variable displacement pump A4VSO, series 2 and 3

### Input power and flow

(operating fluid: hydraulic oil ISO VG 46 DIN 51519, t = 50°C)

Overall efficiency: 
$$\eta_t = \frac{q_v \cdot p}{P_{q_v \max} \cdot 600}$$

Volumetric efficiency: 
$$\eta_v = \frac{q_v}{q_{v\text{theor}}}$$

#### Nominal size 355

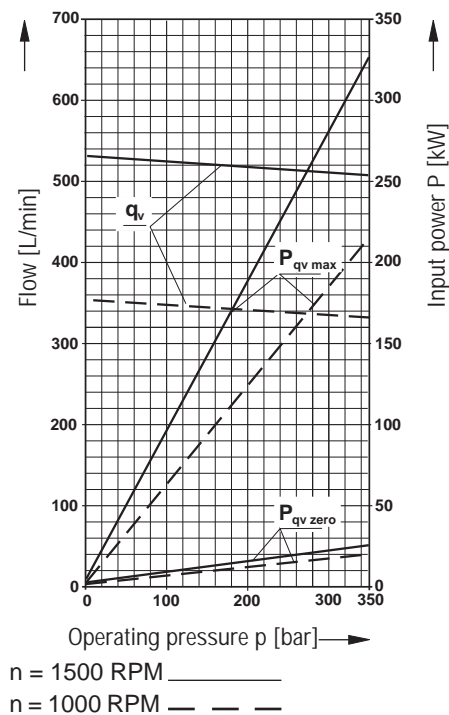

#### Nominal size 500

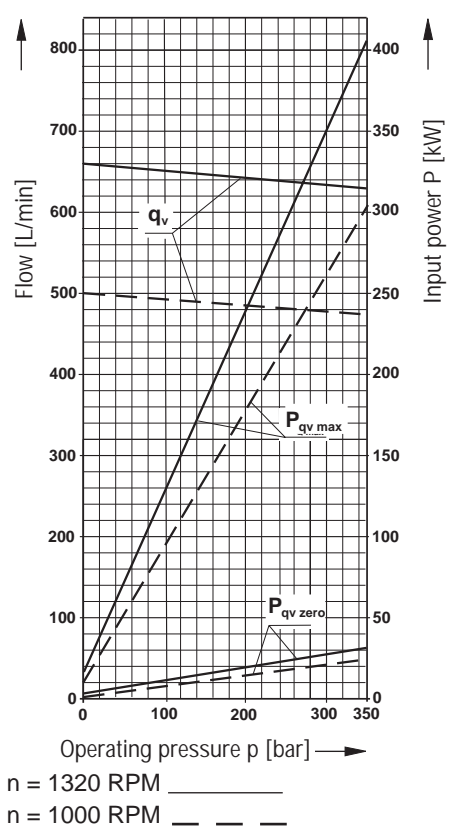

#### Nominal size 750

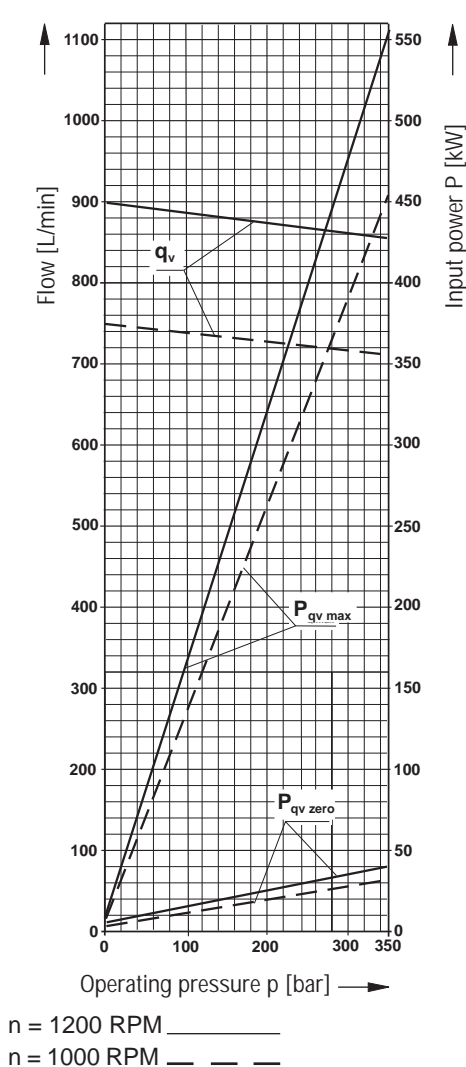

Variable displacement pump A4VSO, series 3

**Input power and flow**(operating fluid: hydraulic oil ISO VG 46 DIN 51519,  $t = 50^\circ\text{C}$ )

$$\text{Overall efficiency: } \eta_t = \frac{q_v \cdot p}{P_{q_v \max} \cdot 600}$$

$$\text{Volumetric efficiency: } \eta_v = \frac{q_v}{q_{v\text{theor}}}$$

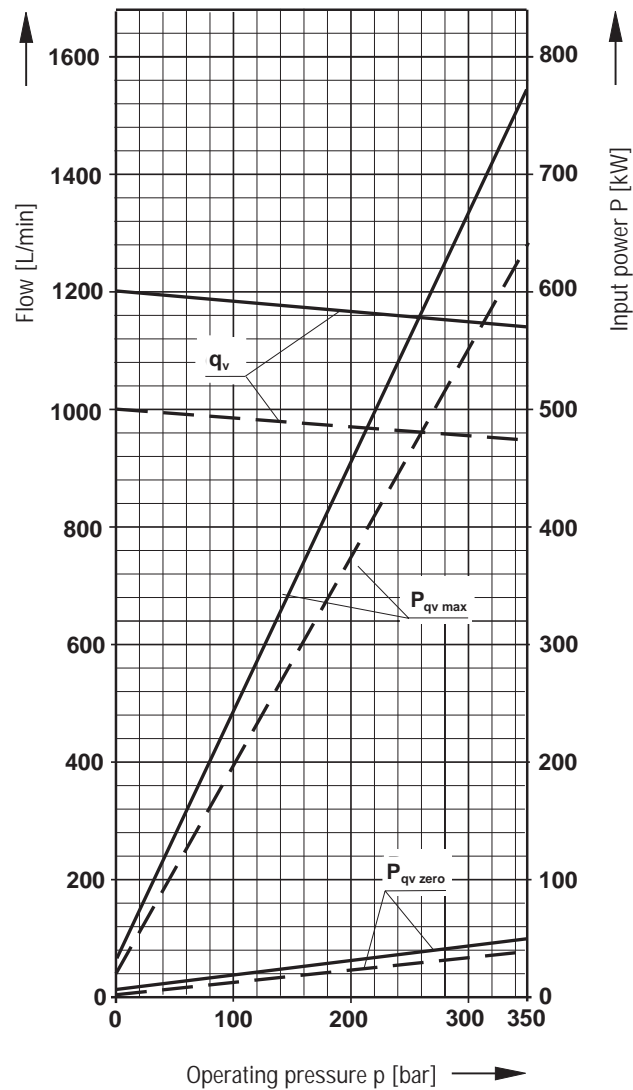
**Nominal size 1000**

$n = 1200 \text{ RPM}$  ———  
 $n = 1000 \text{ RPM}$  - - -



## Installation notes

### Installation position:

Optional. The pump casing must be filled with fluid during commissioning and remain full when operating.

In order to reduce noise output, all connecting lines (suction, pressure and case drain lines) must be de-coupled from the tank using flexible elements.

The use of check valves in the case drain line has to be avoided. Drain oil must be returned directly to the tank without a reduction in cross-section.

Exceptions may be possible after consultations with ourselves.

### 1. Vertical installation (shaft end pointing upwards)

With a vertical installation, bearing flushing is recommended to provide lubrication for the front bearing, see page 4.

The following installation conditions are to be taken into account:

#### 1.1 Installation in a tank

a) When the minimum fluid level is the same as or is above the pump flange area then: ports »R/L«, »T« and »S« are open (see fig. 1).

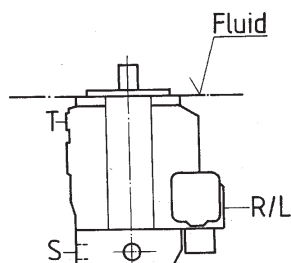

Fig. 1

b) If the minimum fluid level lies under the pump flange area then: ports »R/L«, »T« and possibly »S« have to be piped as shown in fig. 2. The conditions stated in point 1.2 apply.

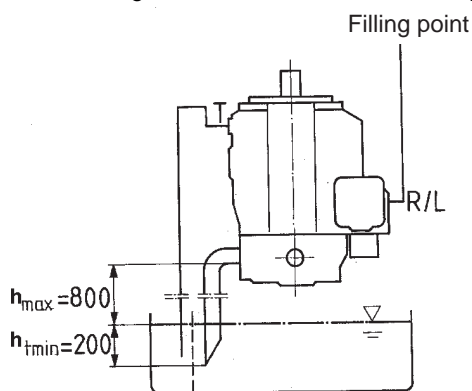

Fig. 2

#### 1.2 Installation outside of a tank

Before installation fill the pump casing with the pump lying in a horizontal position. Port »T« to the tank, »R/L« are plugged. Filling possibilities in the installed condition: fill via »R« bleed via »T«, afterwards plug port »R«.

**Conditions:** A minimum pump inlet pressure (suction pressure) of 0.8 bar abs. must be observed. Avoid mounting the pump above the tank if low noise operation is required.

### 2. Horizontal installation

The highest situated ports »T«, »K<sub>1</sub>«, »K<sub>2</sub>« or »R/L« must be utilised for filling/bleeding and subsequently used as the drain connection.

#### 2.1 Installation in a tank

a) When the minimum fluid level is the same as or lies above the upper edge of the pump then: drain port and port »S« are open (see fig. 3).

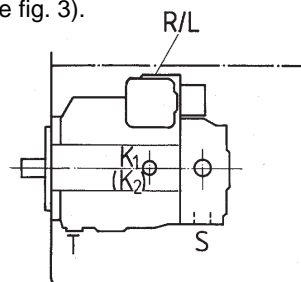

Fig. 3

b) When the minimum fluid level lies under the pump upper edge then: drain port and possibly port »S« has to be piped, see fig. 4. Conditions are as per point 1.2.

Fill pump casing before commissioning.

#### 2.2 Installation outside a tank

Fill the pump housing before commissioning.

a) For installation above a tank see fig. 4.

Conditions are as per point 1.2.

b) For installation under the tank

Pipe drain port and port »S« as per fig. 5.

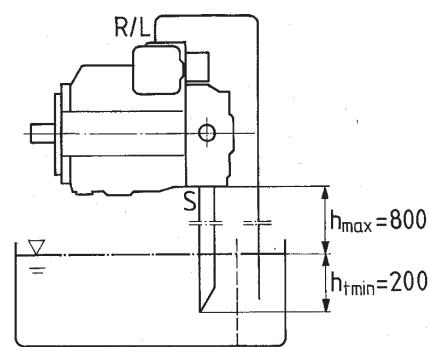

Fig. 4

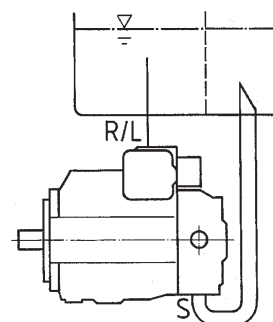
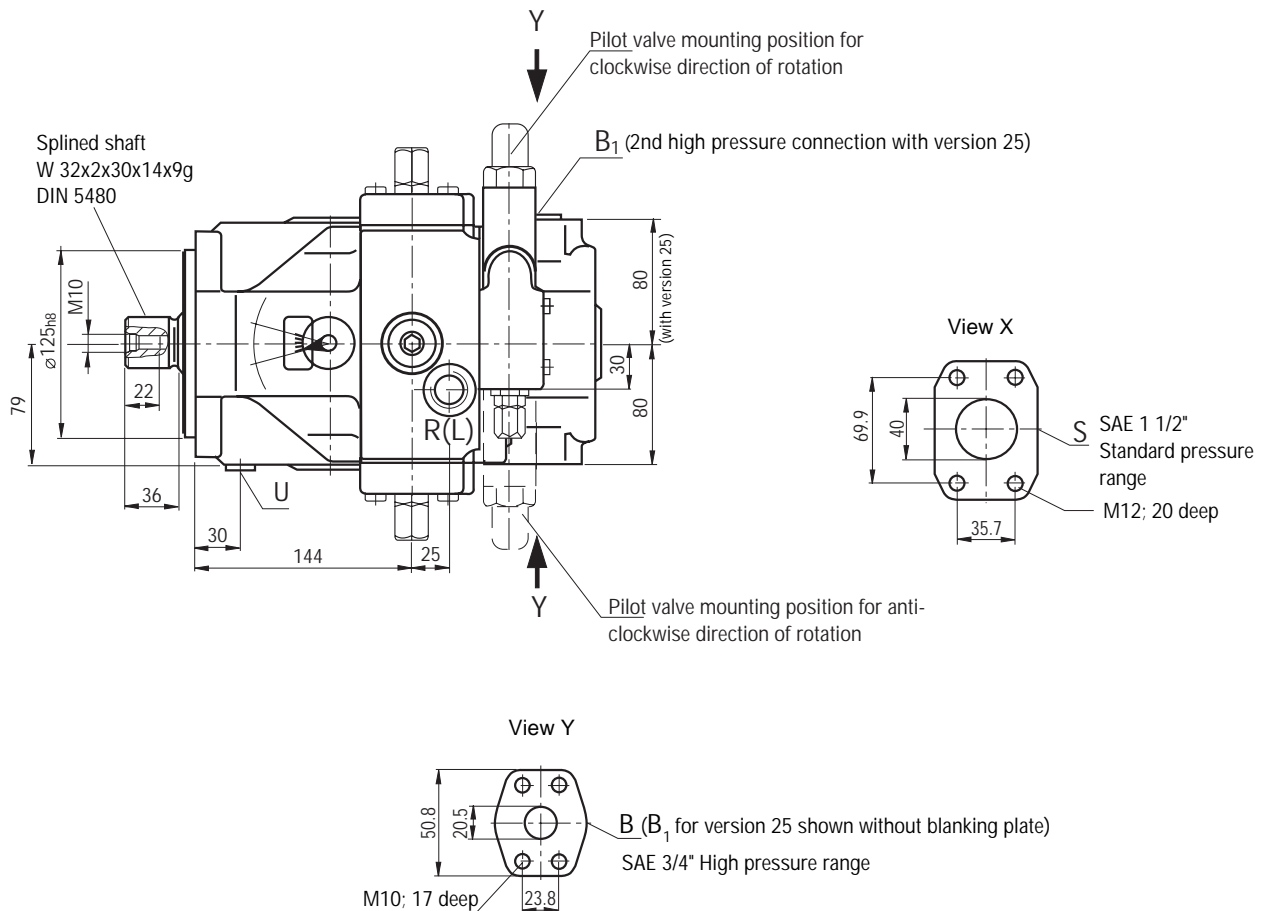
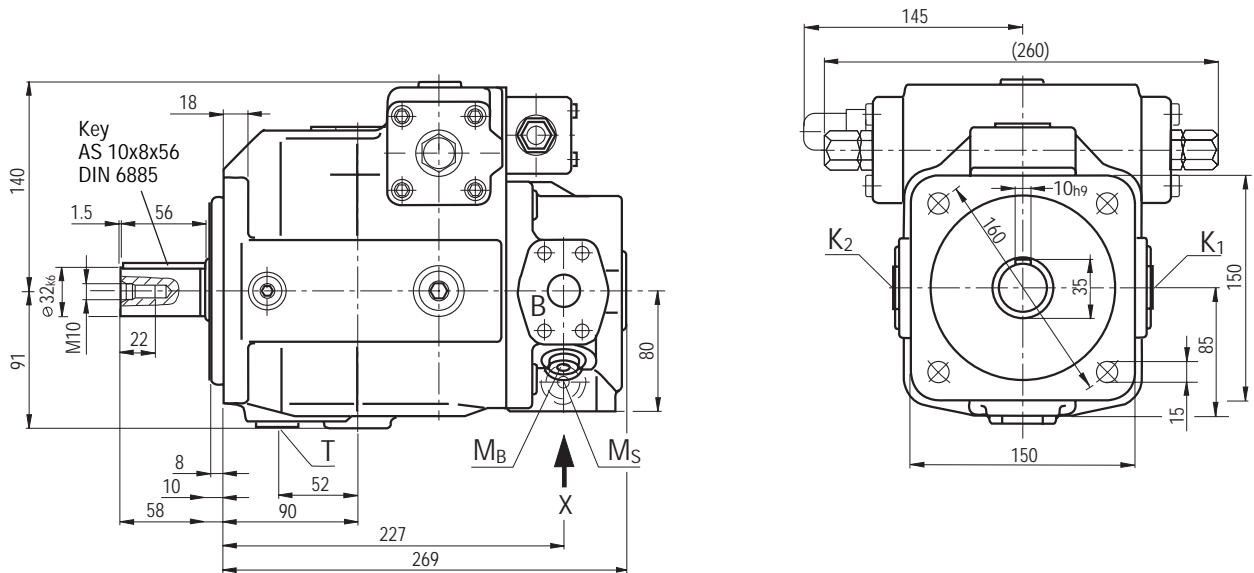

Fig. 5

**Unit dimensions nominal size 40, series 1**

(Example: Pressure control; for exact dimensions of control devices see separate RE sheets)

**Connections for version 13**

B	Pressure port	SAE 3/4" (high pressure range)
B <sub>1</sub>	Auxiliary port	M 22x1.5; 14 deep (plugged)

**Connections for version 25**

B	Pressure port	SAE 3/4" (high pressure range)
B <sub>1</sub>	2nd pressure port	SAE 3/4" (high pressure range) (closed)

**Connections**

S	Suction port	SAE 1 1/2" (standard series)
K <sub>1</sub> , K <sub>2</sub>	Flushing ports	M 22x1.5; 14 deep (plugged)
T	Oil drain	M 22x1.5; 14 deep (plugged)
M <sub>B</sub> , M <sub>S</sub>	Test points	M 14x1.5; 12 deep (plugged)
R(L)	Oil filling + air bleed	M 22x1.5; for exact position refer to the individual data sheet for the control devices
U	Flushing port	M 14x1.5; 12 deep (plugged)

### Unit dimensions nominal size 71, series 1

((Example: Pressure control; for exact dimensions of control devices see separate RE sheets))

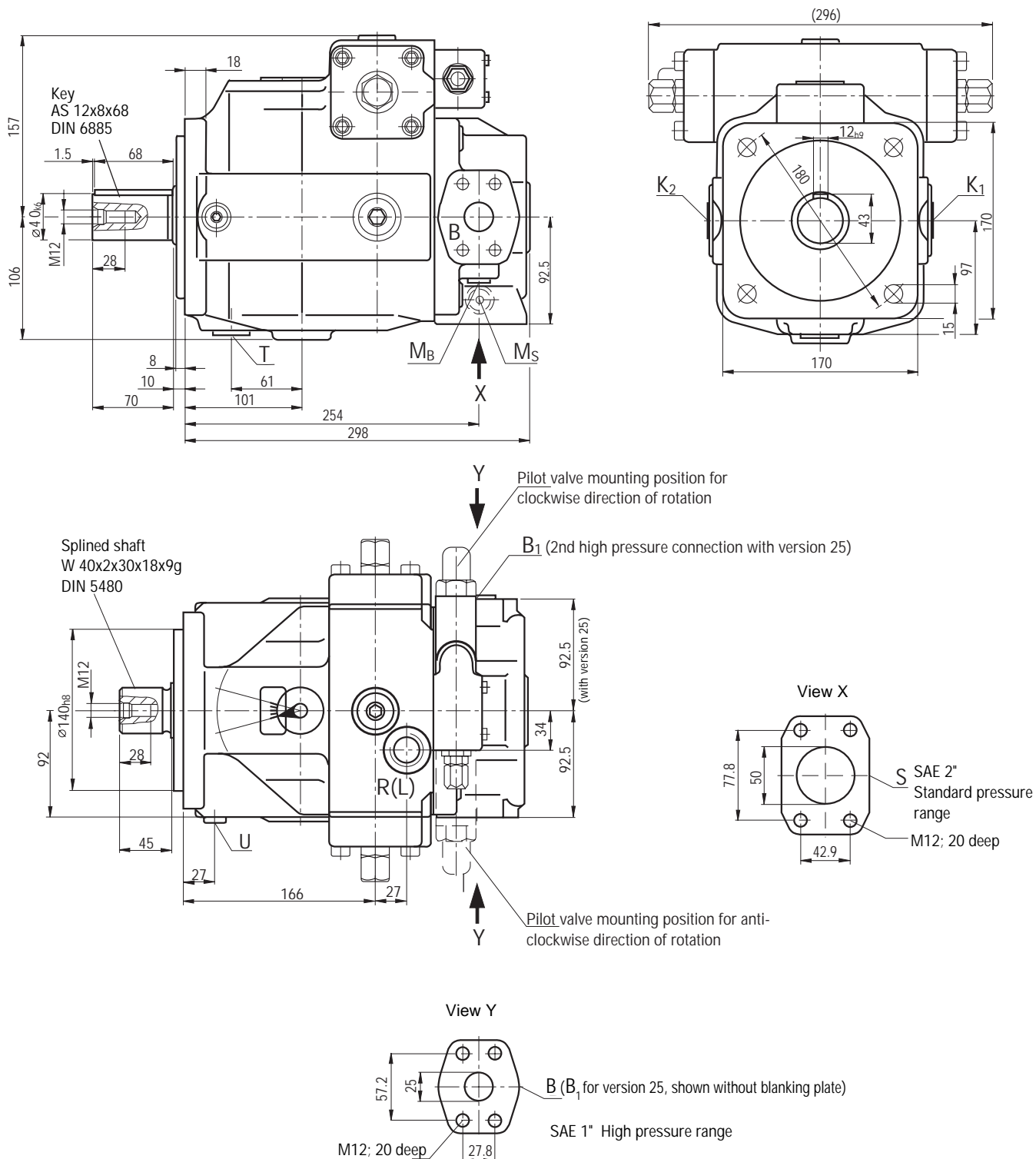

**Connections for version 13**

- B Pressure port SAE 1" (high pressure range)
- B<sub>1</sub> Auxiliary port M 27x2; 16 deep (plugged)

**Connections for version 25**

- B Pressure port SAE 1" (high pressure range)
- B<sub>1</sub> 2nd pressure port SAE 1" (high pressure range) (closed)

**Connections**

- S Suction port SAE 2" (standard series)
- K<sub>1</sub>, K<sub>2</sub> Flushing ports M 27x2; 16 deep (plugged)
- T Oil drain M 27x2; 16 deep (plugged)
- M<sub>B</sub>, M<sub>S</sub> Test points M 14x1.5; 12 deep (plugged)
- R(L) Oil filling + air bleed M 27x2; for exact position refer to the individual data sheet for the control devices
- U Flushing port M 14x1.5; 12 deep (plugged)

**Unit dimensions nominal size 125, series 2 and 3**

(Example: Pressure control series 3; for exact dimensions of control devices see separate RE sheets)

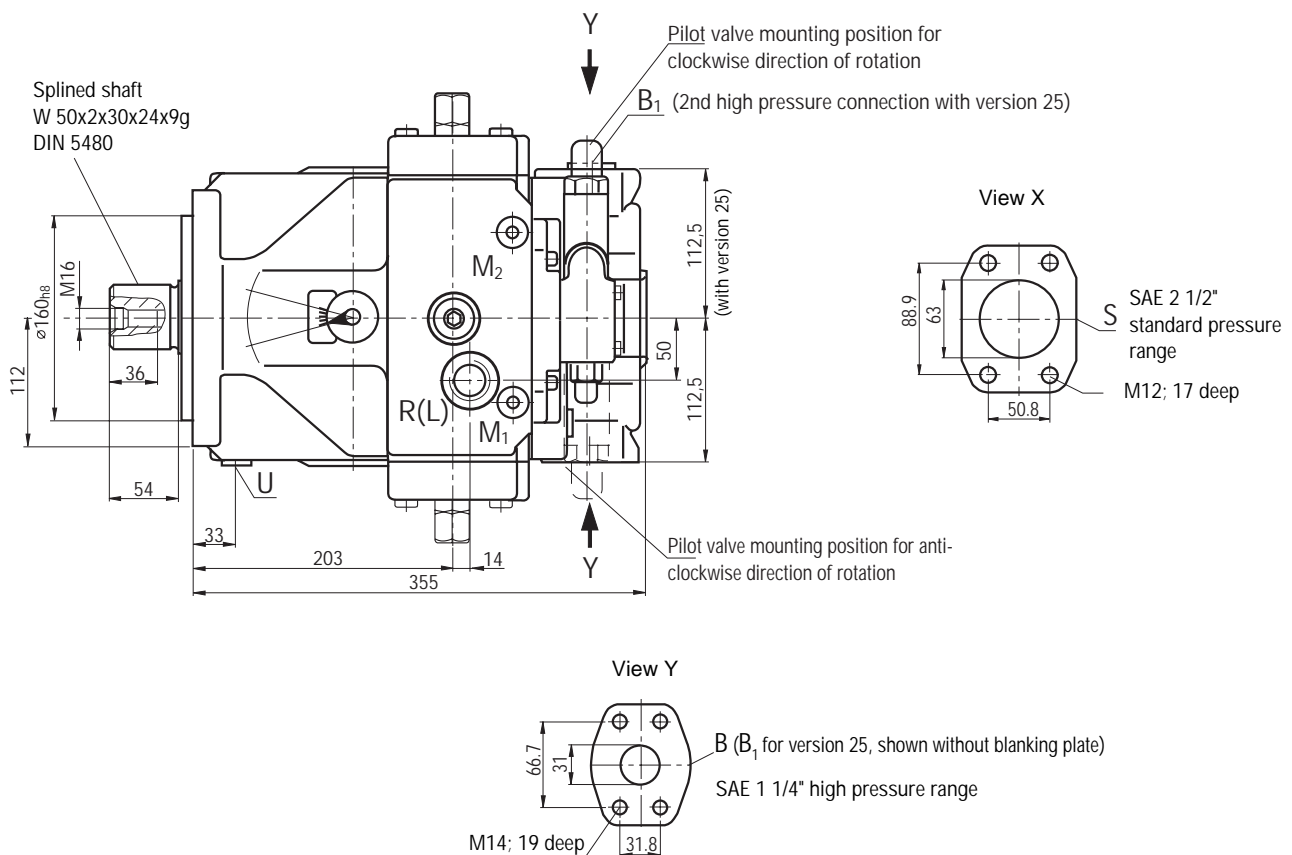
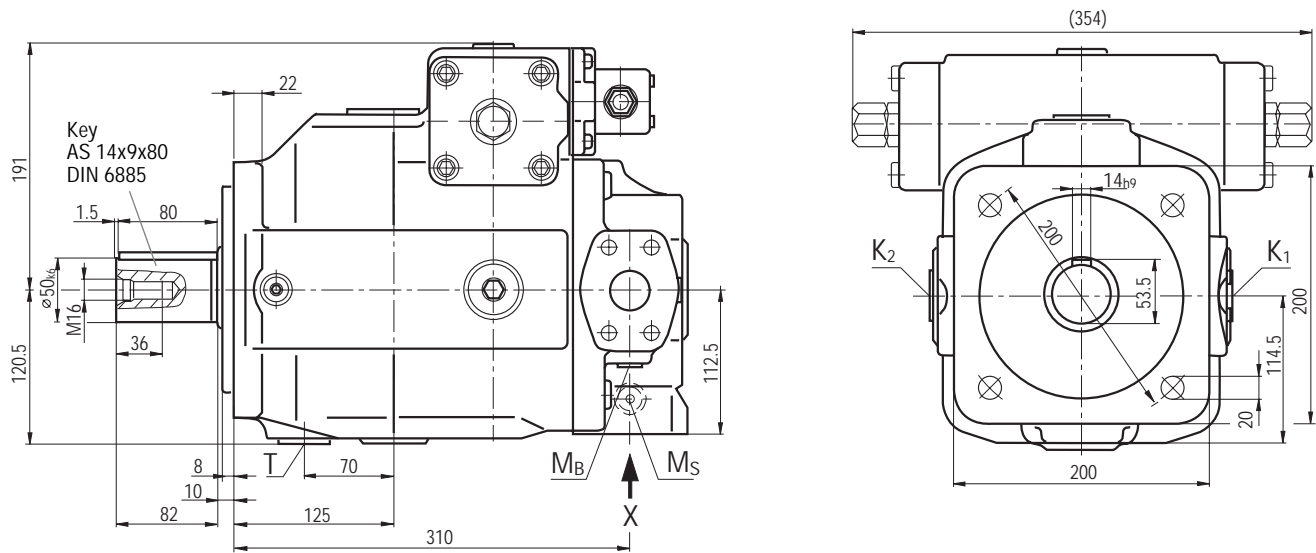
**Connections for version 13**

B	Pressure port	SAE 1 1/4" (high pressure range)
B <sub>1</sub>	Auxiliary port	M 33x2; 18 deep (plugged)

**Connections for version 25**

B	Pressure port	SAE 1 1/4" (high pressure range)
B <sub>1</sub>	2nd pressure port	SAE 1 1/4" (high pressure range) (closed)

**Connections**

S	Suction port	SAE 2 1/2" (standard series)
K <sub>1</sub> , K <sub>2</sub>	Flushing ports	M 33x2; 18 deep (plugged)
T	Oil drain	M 33x2; 18 deep (plugged)
M <sub>B</sub> , M <sub>S</sub>	Test points	M 14x1.5; 12 deep (plugged)
R(L)	Oil filling + air bleed	M 33x2; for exact position refer to the individual data sheet for the control devices
U	Flushing port	M 14x1.5; 12 deep (plugged)
M <sub>1</sub> , M <sub>2</sub>	Test points for adjustment pressure	M 14x1.5 (plugged) only with series 3

**Unit dimensions nominal size 180, series 2 and 3**

(Example: Pressure control series 3; for exact dimensions of control devices see separate RE sheets)

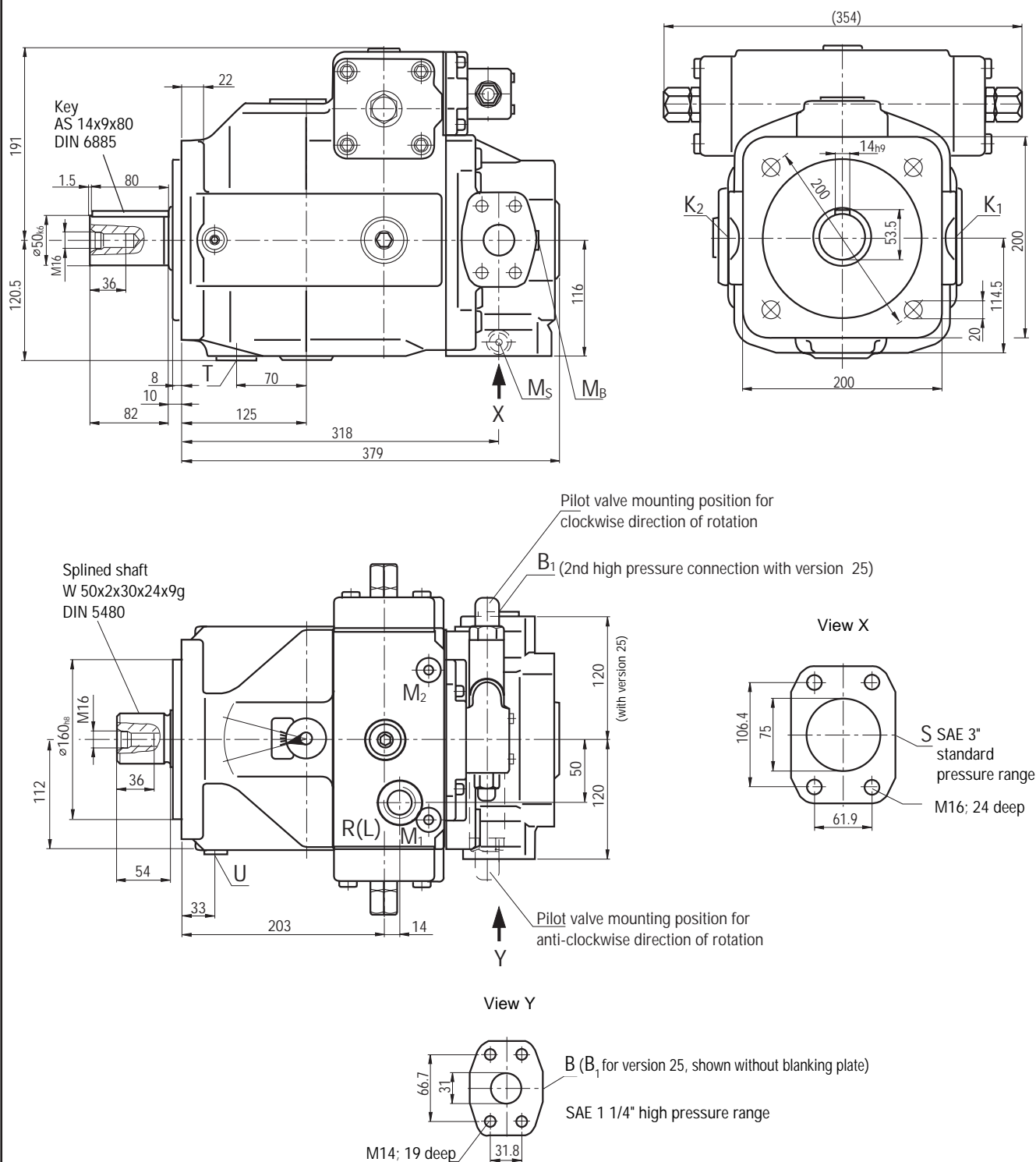
**Connections for version 13**

B	Pressure port	SAE 1 1/4" (high pressure range)
$B_1$	Auxiliary port	M 33x2; 18 deep (plugged)

**Connections of version 25**

B	Pressure port	SAE 1 1/4" (high pressure range)
$B_1$	2nd pressure port	SAE 1 1/4" (high pressure range) (closed)

**Connections**

S	Suction port	SAE 3" (standard series)
$K_1, K_2$	Flushing ports	M 33x2; 18 deep (plugged)
T	Oil drain	M 33x2; 18 deep (plugged)
$M_B, M_S$	Test points	M 14x1.5; 12 deep (plugged)
R(L)	Oil filling + air bleed	M 33x2; for exact position refer to the individual data sheet for the control devices
U	Flushing port	M 14x1.5; 12 deep (plugged)
$M_1, M_2$	Test points for adjustment pressure	M 14x1.5 (plugged) only with series 3

**Unit dimensions nominal size 250, series 3**

(Example: Pressure control; for exact dimensions of control devices see separate RE sheets)

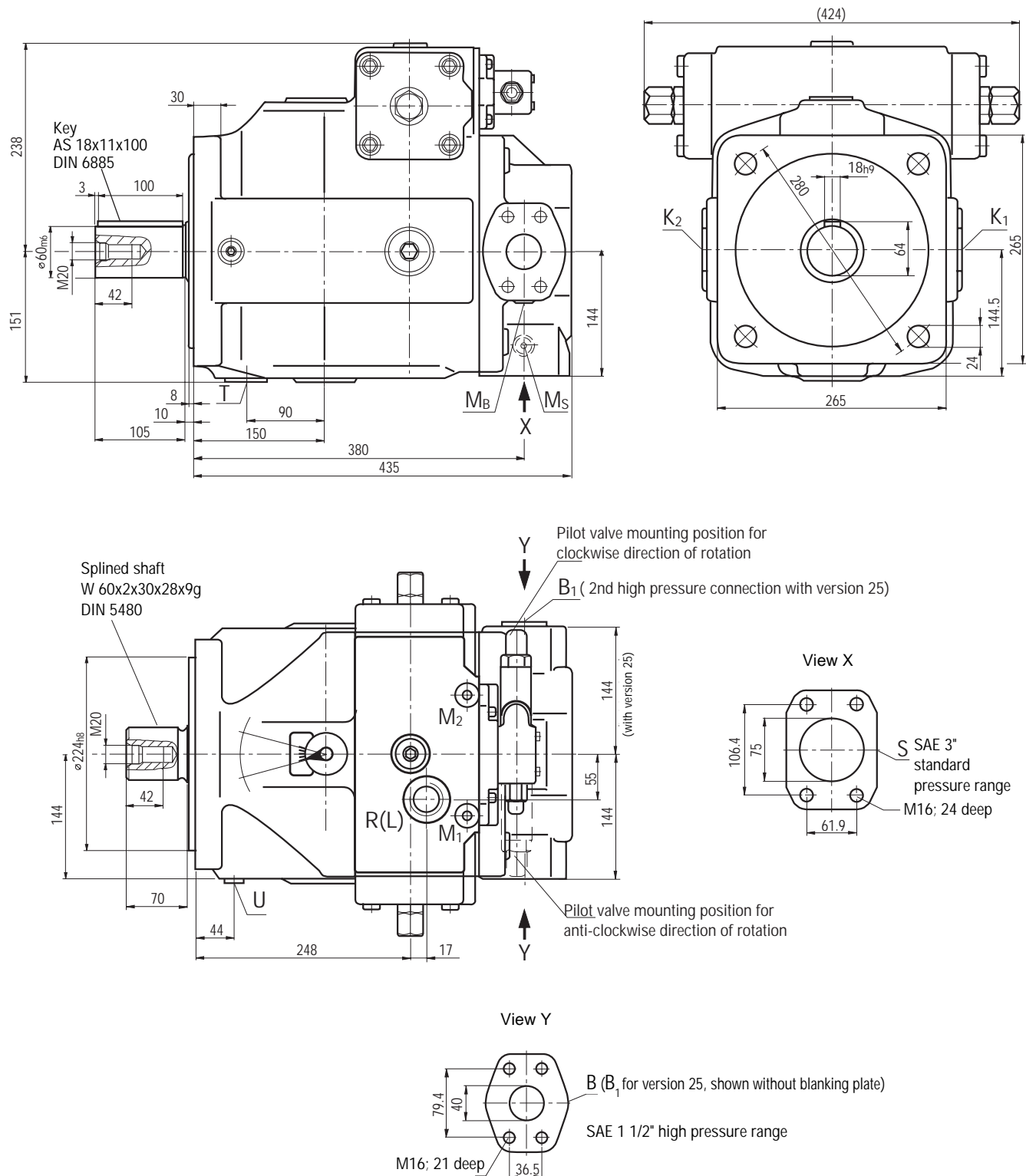
**Connections for version 13**

B	Pressure port	SAE 1 1/2" (high pressure range)
B <sub>1</sub>	Auxiliary port	M 42x2;20 deep (plugged)

**Connections for version 25**

B	Pressure port	SAE 1 1/2" (high pressure range)
B <sub>1</sub>	2nd pressure port	SAE 1 1/2" (high pressure range) (closed)

**Connections**

S	Suction port	SAE 3" (standard series)
K <sub>1</sub> , K <sub>2</sub>	Flushing ports	M 42x2;20 deep (plugged)
T	Oil drain	M 42x2;20 deep (plugged)
M <sub>B</sub> , M <sub>S</sub>	Test points	M 14x1.5;12 deep (plugged)
R(L)	Oil filling + air bleed	M 42x2; for exact position refer to the individual data sheet for the control devices
U	Flushing port	M 14x1.5;12 deep (plugged)
M <sub>1</sub> , M <sub>2</sub>	Test points for adjustment pressure	M 18x1.5 (plugged)

### Unit dimensions nominal size 355, series 2 and 3

(Example: Pressure control series 3; for exact dimensions of control devices see separated RE sheets)

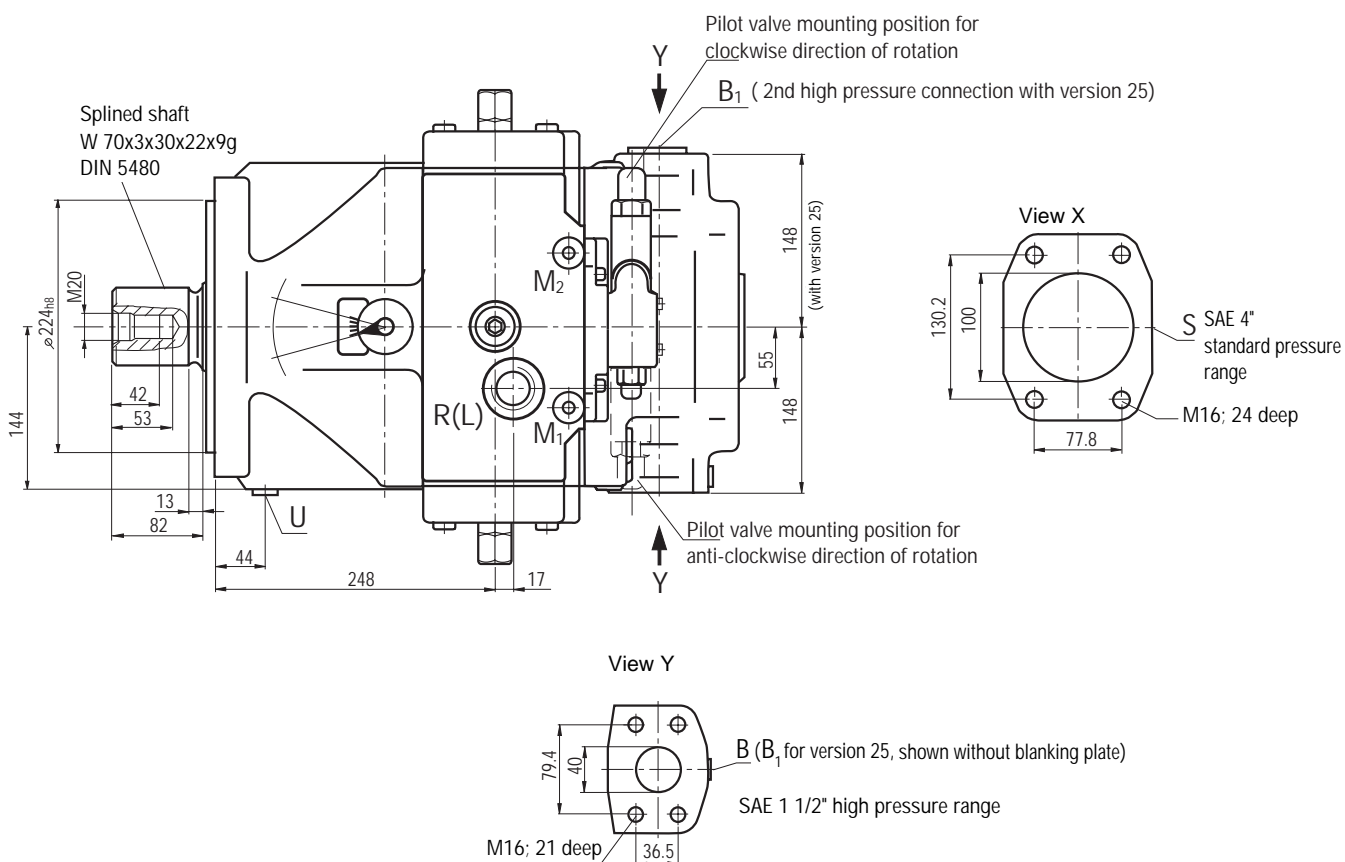
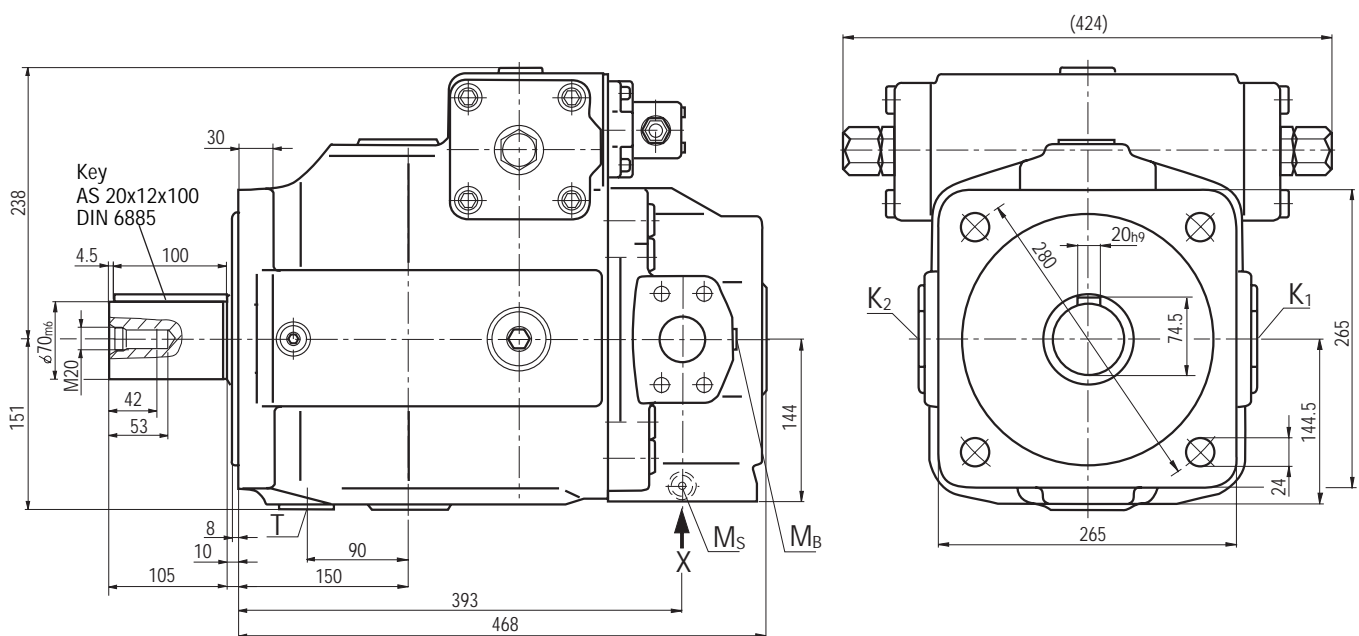

#### Connections for version 13

B Pressure port SAE 1 1/2" (high pressure range)  
B<sub>1</sub> Auxiliary port M 42x2;20 deep (plugged)

#### Connections for version 25

B Pressure port SAE 1 1/2" (high pressure range)  
B<sub>1</sub> 2nd pressure port SAE 1 1/2" (high pressure range) (closed)

#### Connections

S Suction port SAE 4" (standard series)  
K<sub>1</sub>, K<sub>2</sub> Flushing ports M 42x2;20 deep (plugged)  
T Oil drain M 42x2;20 deep (plugged)  
M<sub>B</sub>, M<sub>S</sub> Test points M 14x1.5;12 deep (plugged)  
R(L) Oil filling + air bleed M 42x2;  
for exact position refer to the individual data sheet for the control devices  
U Flushing port M 18x1.5;12 deep (plugged)  
M<sub>1</sub>, M<sub>2</sub> Test points for adjustment pressure M 18x1.5 (plugged) only with series 3

### Unit dimensions nominal size 500, series 3

(Example: Pressure control; for exact dimensions of control devices see separate RE sheets)

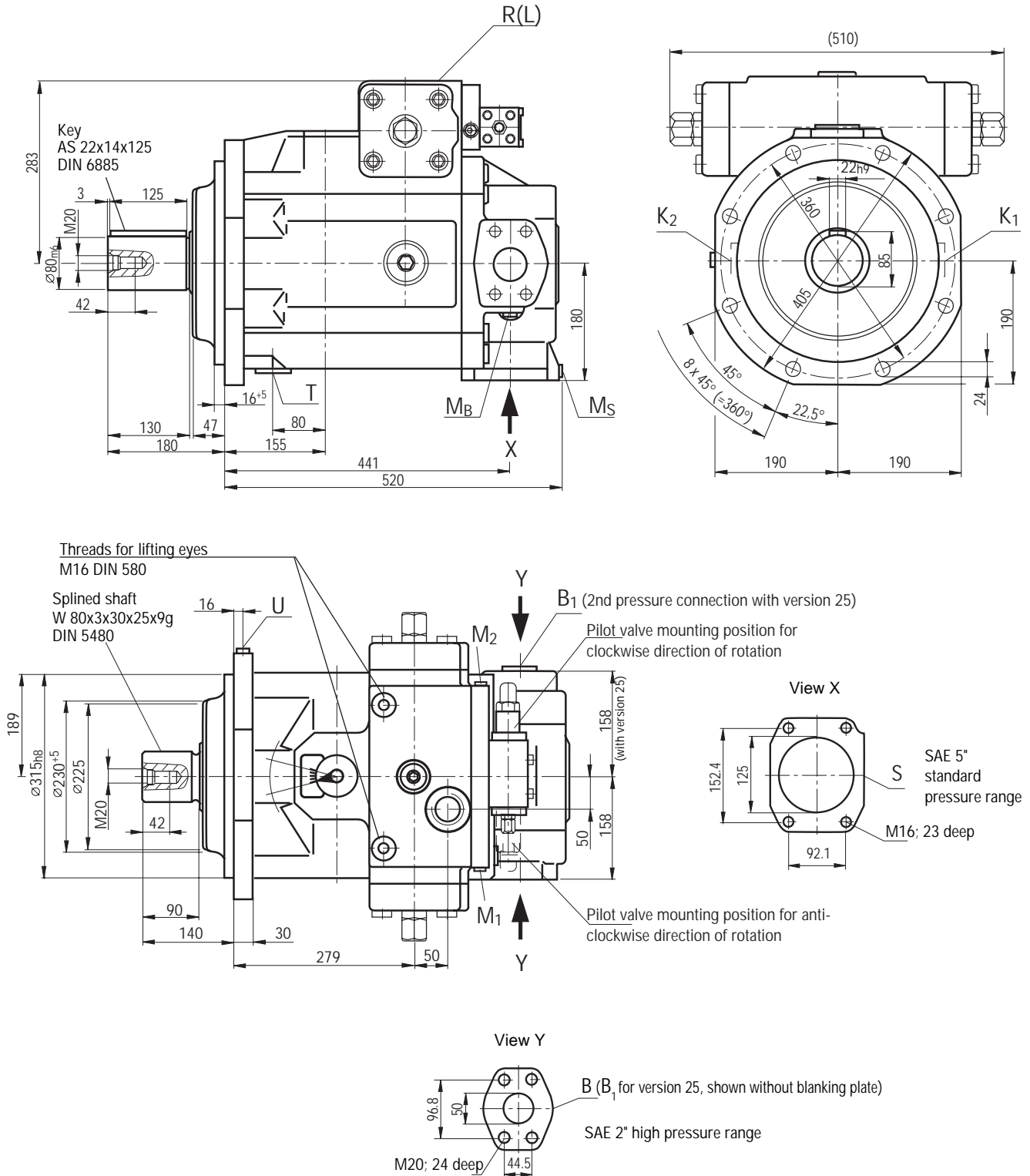

#### Connections for version 13

B	Pressure port	SAE 2" (high pressure range)
B <sub>1</sub>	Auxiliary port	M 48x2; 22 deep (plugged)

#### Connections for version 25

B	Pressure port	SAE 2" (high pressure range)
B <sub>1</sub>	2nd pressure port (closed)	SAE 2" (high pressure range)

#### Connections

S	Suction port	SAE 5" (standard series)
K <sub>1</sub> , K <sub>2</sub>	Flushing ports	M 48x2; 22 deep (plugged)
T	Oil drain	M 48x2; 22 deep (plugged)
M <sub>B</sub> , M <sub>S</sub>	Test points	M 18x1,5; 12 tief (plugged)
R(L)	Oil filling + air bleed	M 48x2; for exact position see individual data sheet for the control devices
U	Flushing port	M 18x1,5; 12 deep (plugged)
M <sub>1</sub> , M <sub>2</sub>	Test points for adjustment pressure	M 18x1,5 (plugged)



### Unit dimensions nominal size 750, series 3

(Example: Pressure control; for exact dimensions of control devices see separate RE sheets)

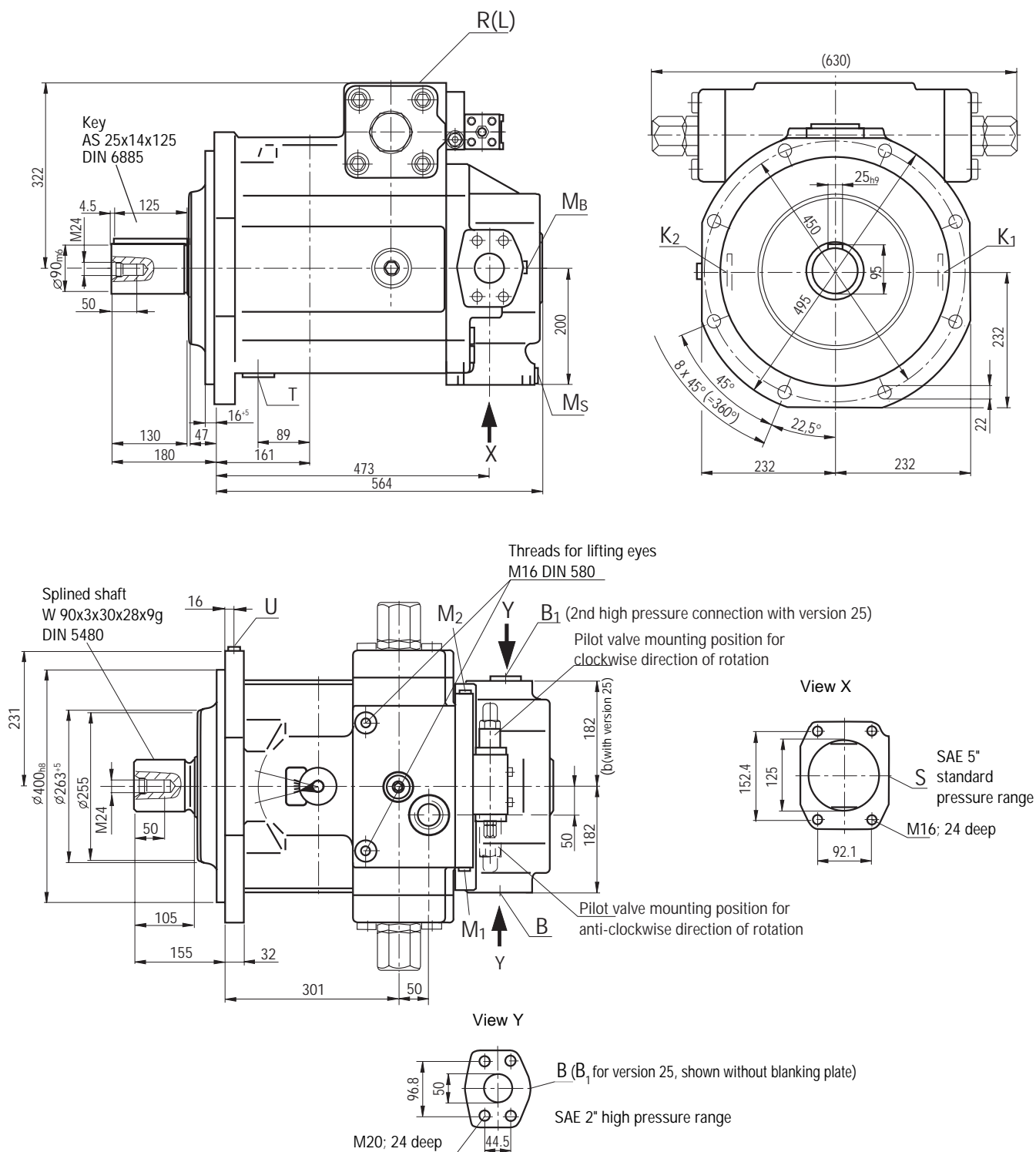

#### Connections for version 13

B Pressure port SAE 2" (high pressure range)  
B<sub>1</sub> Auxiliary port M 48x2;20 deep (plugged)

#### Connections for version 25

B Pressure port SAE 2" (high pressure range)  
B<sub>1</sub> 2nd pressure port SAE 2" (high pressure range) (closed)

#### Connection

S Suction port SAE 5" (standard series)  
K<sub>1</sub>, K<sub>2</sub> Flushing ports M 48x2;20 deep (plugged)  
T Oil drain M 48x2;20 deep (plugged)  
M<sub>B</sub>, M<sub>S</sub> Test points M 18x1.5;12 deep (plugged)  
R(L) Oil filling + air bleed M 48x2;  
for exact position refer to the individual data sheet for the control devices  
U Flushing port M 18x1.5;12 deep (plugged)  
M<sub>1</sub>, M<sub>2</sub> Test points for adjustment pressure M 18x1.5 (plugged)

### Unit dimensions A4VSLO 750 with boost pump (Impeller), series 3

(Example: Pressure control; for exact dimensions of control devices see separate RE sheets)

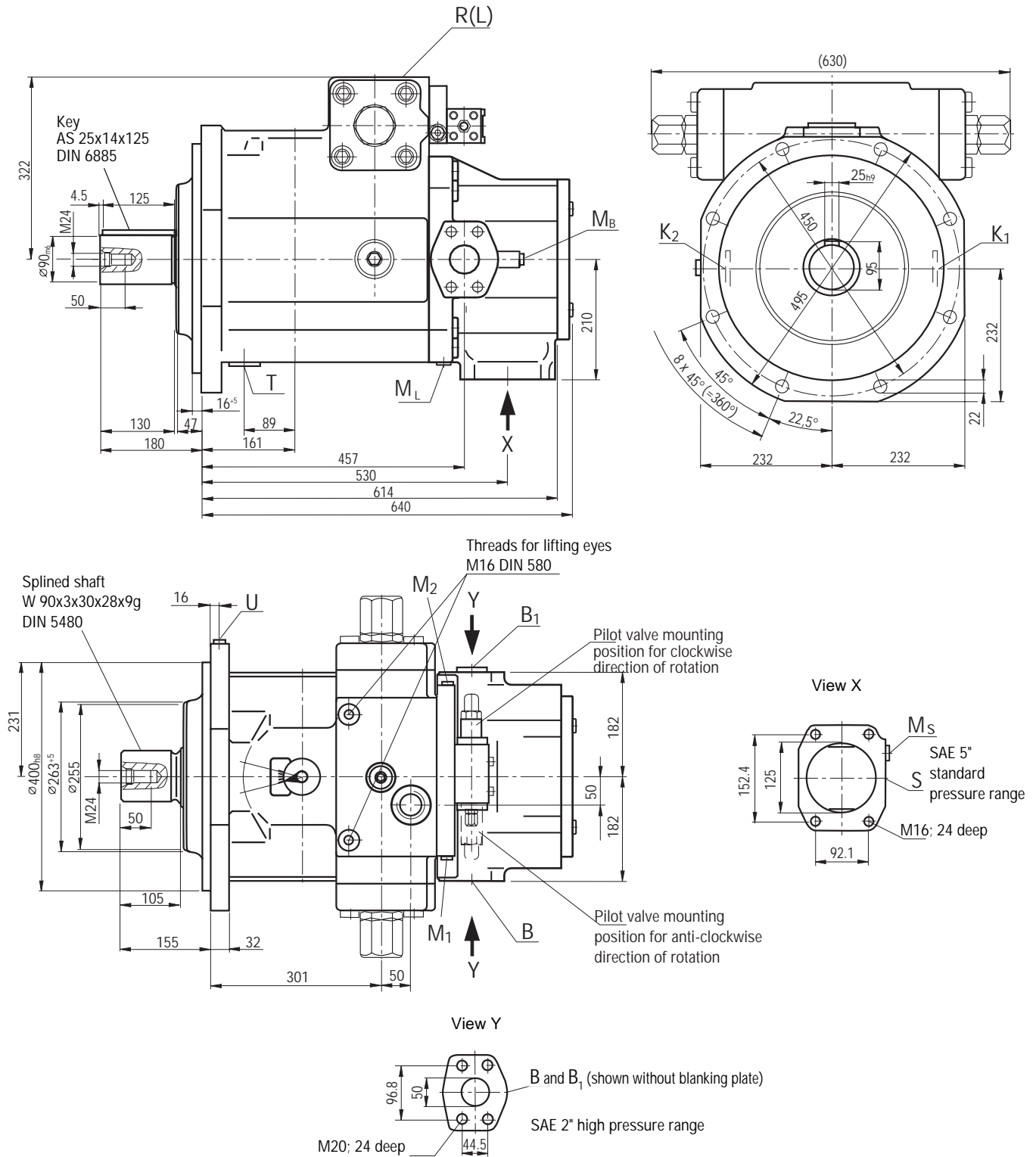

#### Connections – version 25

B	Pressure port	SAE 2" (high pressure range)	M <sub>S</sub>	Test point suction pressure	M 18x1.5; 12 deep (plugged)
B <sub>1</sub>	2nd pressure port	SAE 2" (high pressure range) (closed)	M <sub>L</sub>	Test point boost pressure	M 18x1.5; 12 deep (plugged)
S	Suction port	SAE 5" (standard series)	R(L)	Oil filling + air bleed	M 48x2;
K <sub>1</sub> , K <sub>2</sub>	Flushing ports	M 48x2; 20 deep (plugged)	for exact position refer to the individual data sheet for the control devices		
T	Oil drain	M 48x2; 20 deep (plugged)	U	Flushing port	M 18x1.5; 12 deep (plugged)
M <sub>B</sub>	Test point operating pressure	M 18x1.5; 12 deep (plugged)	M <sub>1</sub> , M <sub>2</sub>	Test points adjustment pressure	M 18x1.5 (plugged)

### Unit dimensions A4VSO 1000, series 3

(Example: Pressure control; for exact dimensions of control devices see separate RE sheets)

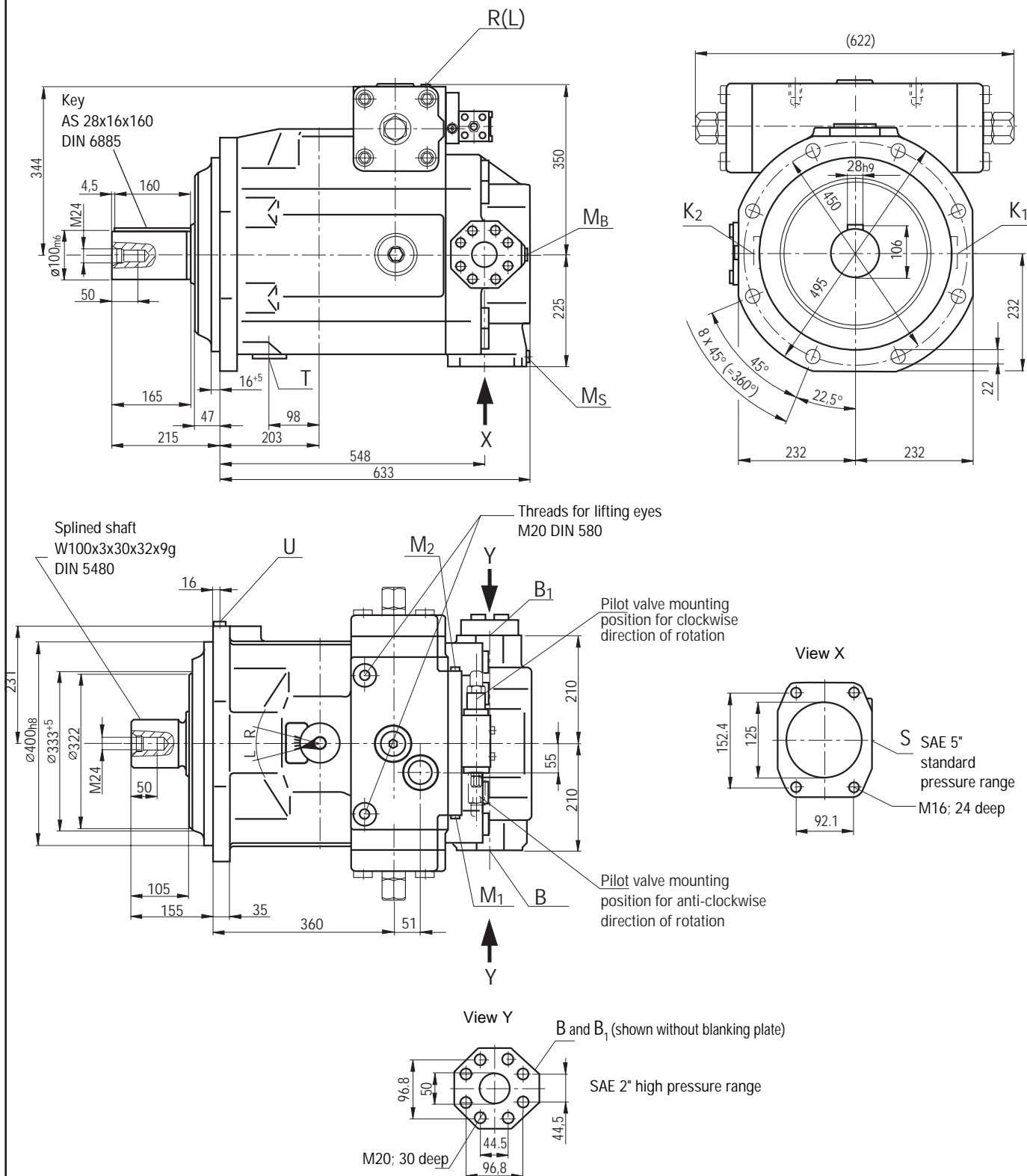

#### Connections – version 25

B	Pressure port	SAE 2" (high pressure range)	M <sub>B</sub>	Test point operating pressure	M 18x1.5;12 deep (plugged)
B <sub>1</sub>	2nd pressure port	SAE 2" (high pressure range)	M <sub>S</sub>	Test point suction pressure	M 18x1.5;12 deep (plugged)
		(closed)	R(L)	Oil filling + air bleed	M 48x2;
S	Suction port	SAE 5" (standard series)	U	Flushing port	M 18x1.5;12 deep (plugged)
K <sub>1</sub> , K <sub>2</sub>	Flushing ports	M 48x2; 20 deep (plugged)	M <sub>1</sub> , M <sub>2</sub>	Test points for adjustment pressure	M 18x1.5 (plugged)
T	Oil drain	M 48x2; 20 deep (plugged)			

**Summary of controls (see RE 92060)**

**Pressure control DR**

Regulates max. pressure in a hydraulic system  
 Setting range 20 – 350 bar  
 Optional:  
 Remote control (DRG)

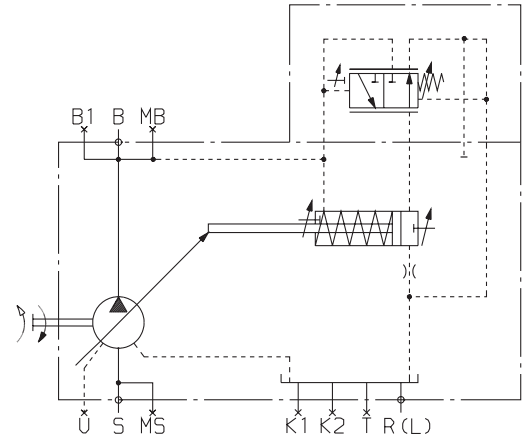
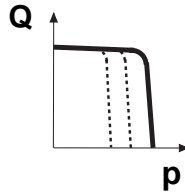

**Pressure control for parallel operation DP**

Suitable for pressure control with multiple axial piston pumps A4VSO in parallel operation.  
 Optional:  
 Flow control (DPF)

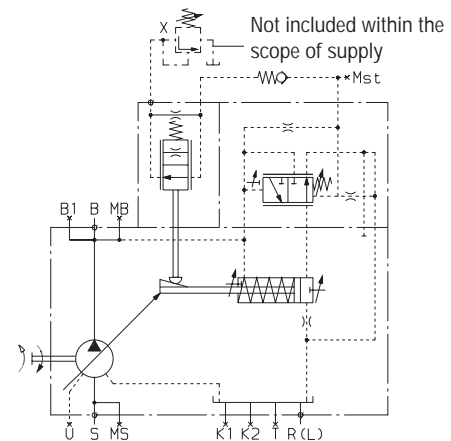
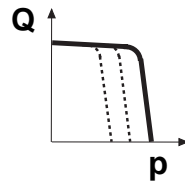

**Flow control FR**

Maintains a constant flow in a hydraulic system (flow)  
 Optional:  
 Remote pressure control (FRG),  
 Orifice in X port plugged (FR1, FRG1)

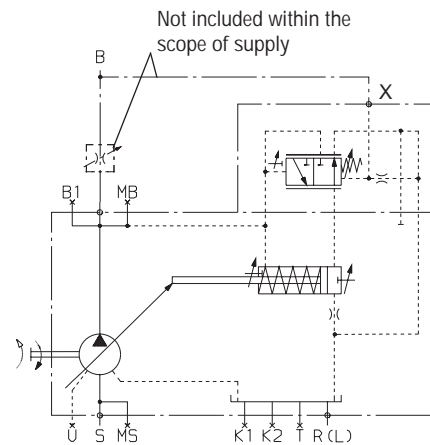
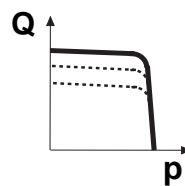

**Pressure and flow control DFR**

This control maintains a constant flow from the pump even under varying operating conditions (flow). Overriding this control is a mechanically adjustable pressure control.  
 Optional:  
 Orifice in X port plugged (DFR1)

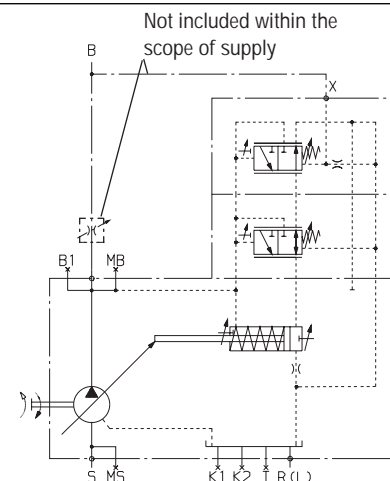
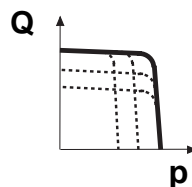

Variable displacement pump A4VSO, series 1 and 2

## Summary of controls (see RE 92064)

### Power control LR2 with hyperbolic curve

The hyperbolic power control maintains a constant preset drive power at the same input speed.

Optional:

Pressure control (LR2D), remote control (LR2G);

Flow control (LR2F, LR2S);

Hydraulic stroke limiter (LR2H);

Mechanical stroke limiter (LR2M);

Hydraulic two-point control (LR2Z);

With electrical unloading valve to assist during start-up (LR2Y).

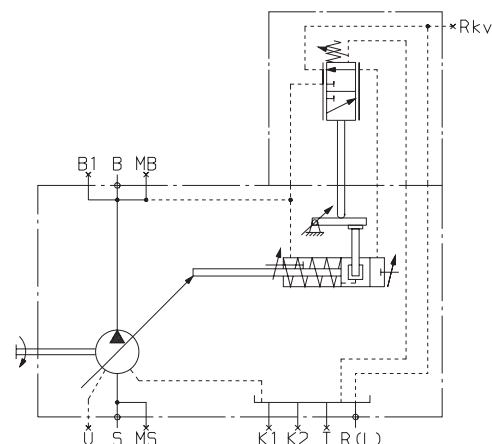
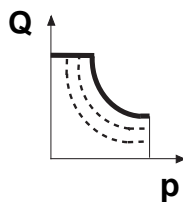

### Power control LR3 with remote control of the power characteristics

The hyperbolic power control maintains a constant preset drive power. The power characteristic curve is remotely adjustable.

Optional:

Pressure control (LR3D), remote control (LR3G);

Flow control (LR3F, LR3S);

Hydraulic stroke limiter (LR3H);

Mechanical stroke limiter (LR3M);

Hydraulic two-point control (LR3Z);

Electrical unloading valve to assist during start-up (LR3Y).

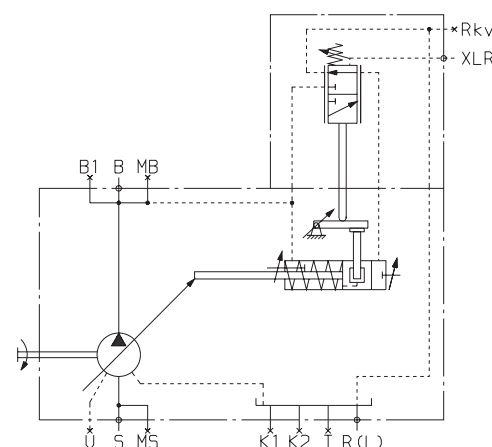
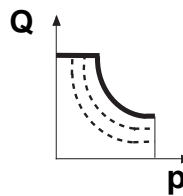

### Hydraulic control LR2N pilot pressure dependent, normally $V_{g \min}$

With overriding power control.

The flow (displacement) is proportional to the pilot pressure in  $P_{\text{pilot}}$ . The additional hyperbolic power control overrides the pilot pressure signal and holds the preset drive power constant.

Optional:

Pressure control (LR2DN), remote control (LR2GN)

Power control characteristic, remotely adjustable (LR3N, LR3DN, LR3GN)

Shown in actuated position  
i.e. P is pressurised

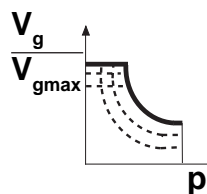
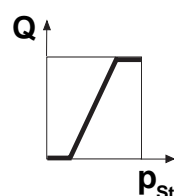
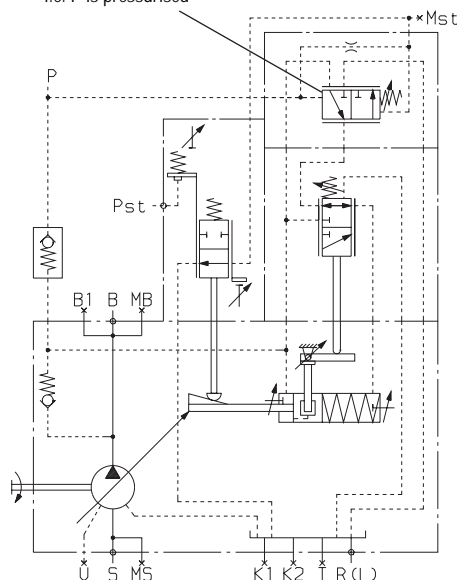

## Summary of controls

### Manual control MA

Stepless flow adjustment by means of a hand-wheel

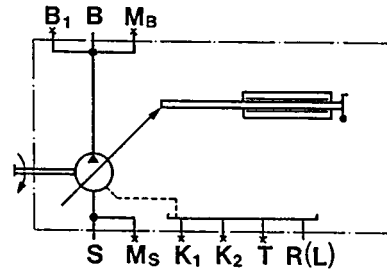
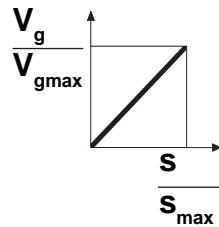

see RE 92072

### Electrical motor control EM

Stepless flow adjustment via an electric motor. With a programmed sequence control, various intermediate displacements can be selected by means of built-on limit switches or a potentiometer.

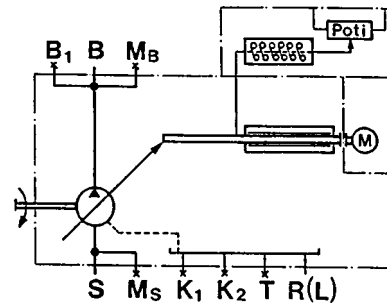
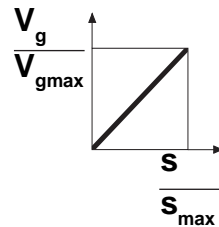

see RE 92072

### Hydraulic control HW position dependent

Stepless flow adjustment (displacement) to the sine.  $\beta$  of the angular position of the pivot. Optional: With hyperbolic power control (HWP)

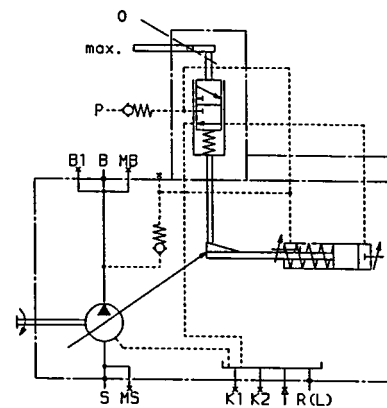
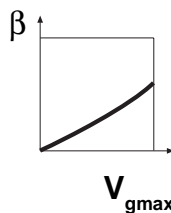

see RE 92068 (in preparation)

### Hydraulic control HD pilot pressure dependent

Stepless flow adjustment of the pump (displacement) in relation to the pilot pressure. The adjustment is proportional to the applied pilot pressure.

Optional:  
 Pilot pressure characteristic curves (HD1, HD2, HD3)  
 Pressure control (HD.B), remote control (HD.GB)  
 Power control (HD1P)  
 Electrical pilot pressure control (HD1T)

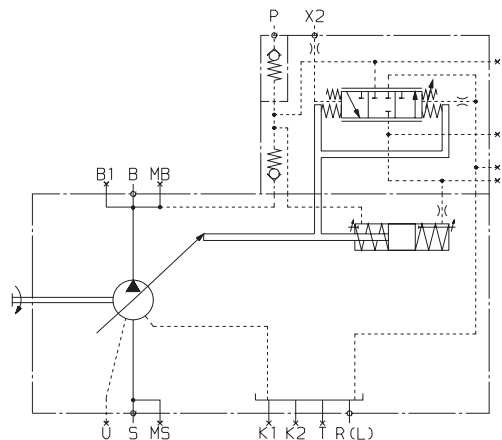
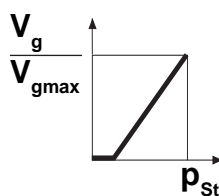

see RE 92080

## Summary of controls

### Hydraulic flow control HM 1/2/3 pilot control flow dependent

The pump flow (displacement) is infinitely adjustable in relation to the pilot oil flow at ports X<sub>1</sub> and X<sub>2</sub>.

- Application:
- 2-point control
  - basic control device for servo or proportional control

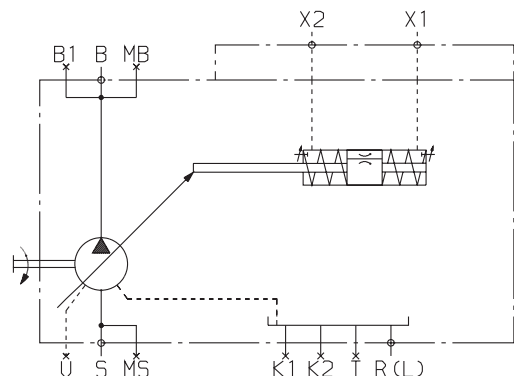

see RE 92076

### Hydraulic flow control HS, HS1, HS3 with servo or proportional valve

The stepless displacement control is accomplished by means of a servo or proportional valve with electrical feedback of the swivel angle.

#### Electronic control

Optional: servo valve (HS/HS1); Proportional valve (HS3); short circuit valve (HSK, HS1K, HS3K); without valves (HSE, HS1E, HS3E). The **HS3P(U)** control is fitted with a built-on pressure transducer so that it can be utilised for **electrical pressure and power control**.

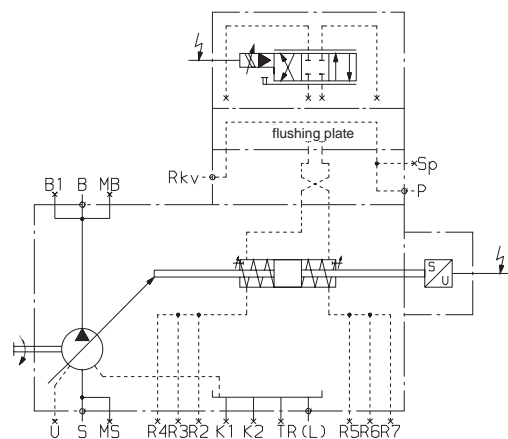
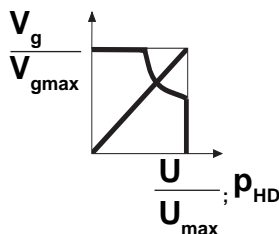

see RE 92076

### Hydraulic flow control EO1/2

The stepless adjustment of the displacement is accomplished by means of a proportional valve with electrical feedback of the swivel angle.

#### Electronically controlled

Optional: Short circuit valve (EO1K, EO2K) Without valves (EO1E, EO2E)

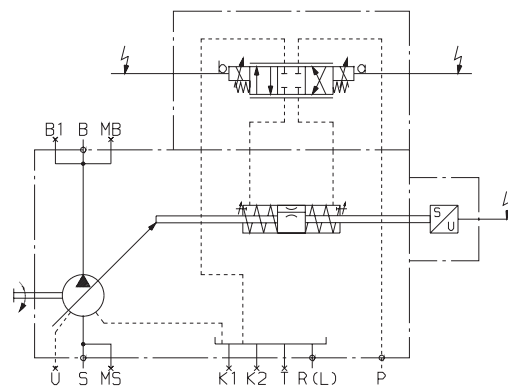
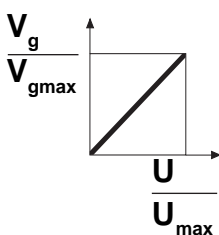

see RE 92076

### Speed control DS1 secondary controlled

The speed control DS1 controls the secondary unit in such a manner that the motor supplies sufficient torque to maintain the required speed. When connected to a constant pressure system, this torque is proportional to displacement and thus also proportional to the swivel angle.

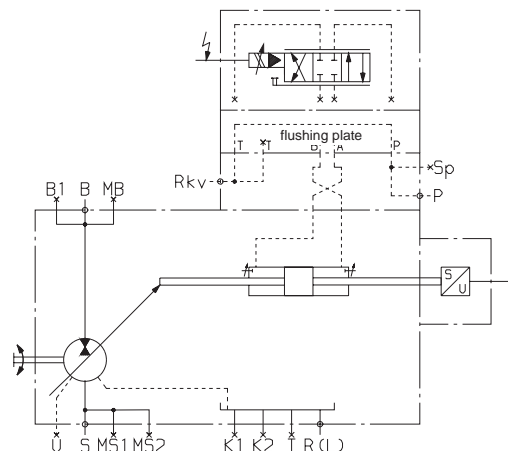
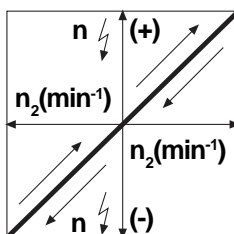

see RE 92055

## Through drive

The axial piston unit A4VSO can be supplied with a through drive, as shown in the ordering details on page 3.

We recommend that only up to a maximum of three individual pumps be coupled in tandem.

Included within the scope of supply are:

Coupling, fixing screws, seals and, where applicable, an adaptor flange.

### Combination pumps

Independent circuits are available for the user when further pumps are built-on.

1. If the combination consists of **2 Brueninghaus units** and if this **is to be factory fitted**, both pump codes should be quoted, joined by "+".

Ordering example:

A4VSO 125 DR/22R – PPB13K33 +

A4VSO 71 DR /10 R – PZB13N00

- 1.1 If a **gear or radial piston pump** is to be fitted in the factory as the 2nd pump, please consult us.

When projecting a combination pump using the same size pumps (e.g. 125 + 125) together with a control device HD.P, HD.T, HD.U please consult us.

### Permissible through drive torque

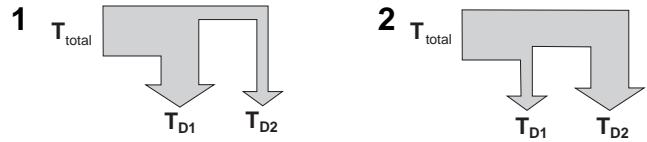

### Splined shaft

Nominal size		40	71	125	180	250	355	500	750	1000		
Max. permissible through drive torque at shaft pump 1 (Pump 1 + Pump 2)		$T_{total\ max}$	Nm	446	790	1392	2004	2782	3952	5566	8348	11130
1	Permissible through drive torque	$T_{D1max}$	Nm	223	395	696	1002	1391	1976	2783	4174	5565
		$T_{D2max}$	Nm	223	395	696	1002	1391	1976	2783	4174	5565
2	Permissible through drive torque	$T_{D1max}$	Nm	223	395	696	1002	1391	1976	2783	4174	5565
		$T_{D2max}$	Nm	223	395	696	1002	1391	1976	2783	4174	5565

### Keyed shaft

Nominal size		40	71	125	180	250	355	500	750	1000		
Max. permissible through drive torque at shaft pump 1 (Pump 1 + Pump 2)		$T_{total\ max}$	Nm	380	700	1392	1400	2300	3557	5200	7513	9444
1	Permissible through drive torque	$T_{D1max}$	Nm	223	395	696	1002	1391	1976	2783	4174	5565
		$T_{D2max}$	Nm	157	305	696	398	909	1581	2417	3339	3879
2	Permissible through drive torque	$T_{D1max}$	Nm	157	305	696	398	909	1581	2417	3339	3879
		$T_{D2max}$	Nm	223	395	696	1002	1391	1976	2783	4174	5565

### Permissible moment of inertia referred to the mounting flange of the main pump

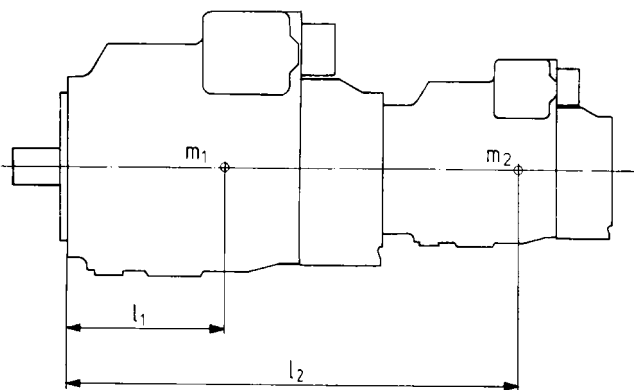

$m_1, m_2$  [kg] Weight of pump  
 $l_1, l_2$  [mm] Centre to centre distance

$$T_m = m_1 \cdot l_1 \cdot \frac{1}{102} + m_2 \cdot l_2 \cdot \frac{1}{102} \text{ [Nm]}$$

Nominal size		40	71	125	180	250	355	500	750	1000	
Permissible moment of inertia	$T_{m\ zul.}$	Nm	1800	2000	4200	4200	9300	9300	15600	19500	19500
Perm. moment of inertia with dynamic mass acceleration $10\ g \hat{=} 98.1\ m/sec^2$	$T_{m\ zul.}$	Nm	180	200	420	420	930	930	1560	1950	1950
Weight (DR)	m	kg	39	53	88	102	184	207	320	460	605
Centre to centre distance	$l_1$	mm	120	140	170	180	210	220	230	260	290



## Unit dimensions of combination pumps

A4VSO + A4VSO

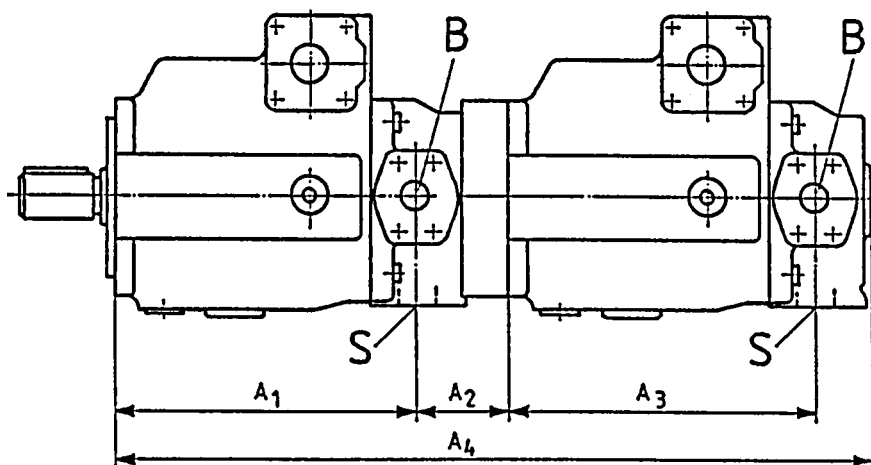

Main pump \ 2nd pump	A4VSO 40				A4VSO 71				A4VSO 125				A4VSO 180				A4VSO 250			
	A <sub>1</sub>	A <sub>2</sub>	A <sub>3</sub>	A <sub>4</sub>	A <sub>1</sub>	A <sub>2</sub>	A <sub>3</sub>	A <sub>4</sub>	A <sub>1</sub>	A <sub>2</sub>	A <sub>3</sub>	A <sub>4</sub>	A <sub>1</sub>	A <sub>2</sub>	A <sub>3</sub>	A <sub>4</sub>	A <sub>1</sub>	A <sub>2</sub>	A <sub>3</sub>	A <sub>4</sub>
A4VSO 40	227	61	227	557	254	62	227	585	310	37	227	616	318	53	227	640	380	51	227	700
A4VSO 71	-	-	-	-	254	62	254	614	310	63	254	671	318	79	254	695	380	51	254	729
A4VSO 125	-	-	-	-	-	-	-	-	310	69	310	734	318	85	310	758	380	89	310	824
A4VSO 180	-	-	-	-	-	-	-	-	-	-	-	-	318	85	318	782	380	89	318	848
A4VSO 250	-	-	-	-	-	-	-	-	-	-	-	-	-	-	-	-	380	89	380	908

Main pump \ 2nd pump	A4VSO 355				A4VSO 500				A4VSO 750				A4VSO 1000			
	A <sub>1</sub>	A <sub>2</sub>	A <sub>3</sub>	A <sub>4</sub>	A <sub>1</sub>	A <sub>2</sub>	A <sub>3</sub>	A <sub>4</sub>	A <sub>1</sub>	A <sub>2</sub>	A <sub>3</sub>	A <sub>4</sub>	A <sub>1</sub>	A <sub>2</sub>	A <sub>3</sub>	A <sub>4</sub>
A4VSO 40	393	67	227	729	441	64	227	774	473	82	227	824	548	*	227	*
A4VSO 71	393	67	254	758	441	64	254	803	473	82	254	853	548	*	254	*
A4VSO 125	393	105	310	853	441	64	310	860	473	82	310	910	548	*	310	*
A4VSO 180	393	105	318	877	441	64	318	884	473	82	318	934	548	*	318	*
A4VSO 250	393	105	380	937	441	100	380	980	473	118	380	1030	548	*	380	*
A4VSO 355	393	105	393	966	441	100	393	1009	473	118	393	1059	548	*	393	*
A4VSO 500	-	-	-	-	441	149	441	1110	473	167	441	1160	548	*	441	*
A4VSO 750	-	-	-	-	-	-	-	-	473	182	473	1219	548	*	473	*
A4VSO 1000	-	-	-	-	-	-	-	-	-	-	-	-	548	180	548	1361

\* on request

**Unit dimensions of combination pumps**

A4VSO + A10VSO

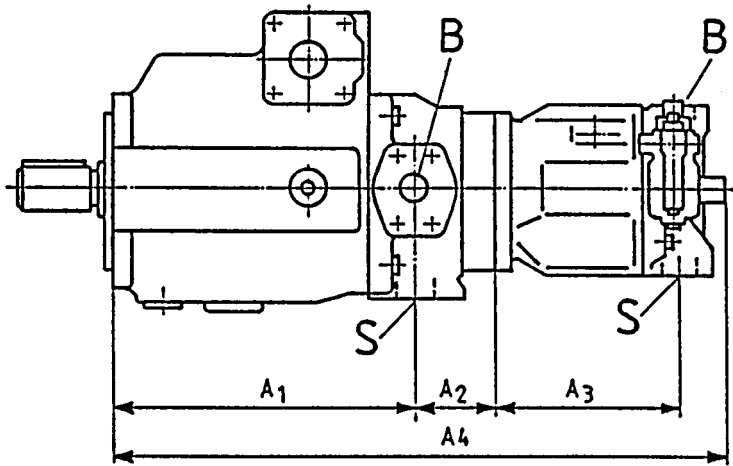

Main pump \ 2nd pump	A4VSO 40				A4VSO 71				A4VSO 125				A4VSO 180				A4VSO 250			
	A <sub>1</sub>	A <sub>2</sub>	A <sub>3</sub>	A <sub>4</sub>	A <sub>1</sub>	A <sub>2</sub>	A <sub>3</sub>	A <sub>4</sub>	A <sub>1</sub>	A <sub>2</sub>	A <sub>3</sub>	A <sub>4</sub>	A <sub>1</sub>	A <sub>2</sub>	A <sub>3</sub>	A <sub>4</sub>	A <sub>1</sub>	A <sub>2</sub>	A <sub>3</sub>	A <sub>4</sub>
<b>A10VSO 18</b>	227	36	145	458	254	37	145	486	310	37	145	542	318	53	145	566	380	51	145	626
<b>A10VSO 28</b>	227	63	164	496	254	37	164	497	310	37	164	553	318	53	164	577	380	51	164	637
<b>A10VSO 45</b>	227	63	184	514	254	57	184	535	310	57	184	591	318	73	184	615	380	51	184	655
<b>A10VSO 71</b>	-	-	-	-	254	67	217	578	310	68	217	635	318	84	217	659	380	69	217	706
<b>A10VSO 100</b>	-	-	-	-	-	-	-	-	310	74.5	275	710.5	318	90.5	275	734.5	380	77	275	783
<b>A10VSO 140</b>	-	-	-	-	-	-	-	-	-	-	-	-	318	*	275	*	380	89	275	806

Main pump \ 2nd pump	A4VSO 355				A4VSO 500				A4VSO 750			
	A <sub>1</sub>	A <sub>2</sub>	A <sub>3</sub>	A <sub>4</sub>	A <sub>1</sub>	A <sub>2</sub>	A <sub>3</sub>	A <sub>4</sub>	A <sub>1</sub>	A <sub>2</sub>	A <sub>3</sub>	A <sub>4</sub>
<b>A10VSO 18</b>	393	67	145	655	441	64	145	700	473	82	145	750
<b>A10VSO 28</b>	393	67	164	666	441	64	164	711	473	82	164	761
<b>A10VSO 45</b>	393	67	184	684	441	64	184	729	473	82	184	779
<b>A10VSO 71</b>	393	85	217	735	441	64	217	762	473	82	217	812
<b>A10VSO 100</b>	393	93	275	812	441	90	275	857	473	108	275	907
<b>A10VSO 140</b>	393	105	275	835	441	89	275	867	473	107	275	917

\* on request

### Dimensions – through drive

**ISO 125, 4-hole;** for mounting an A4VSO/H/G 40 (splined shaft)  
Ordering code **K31**

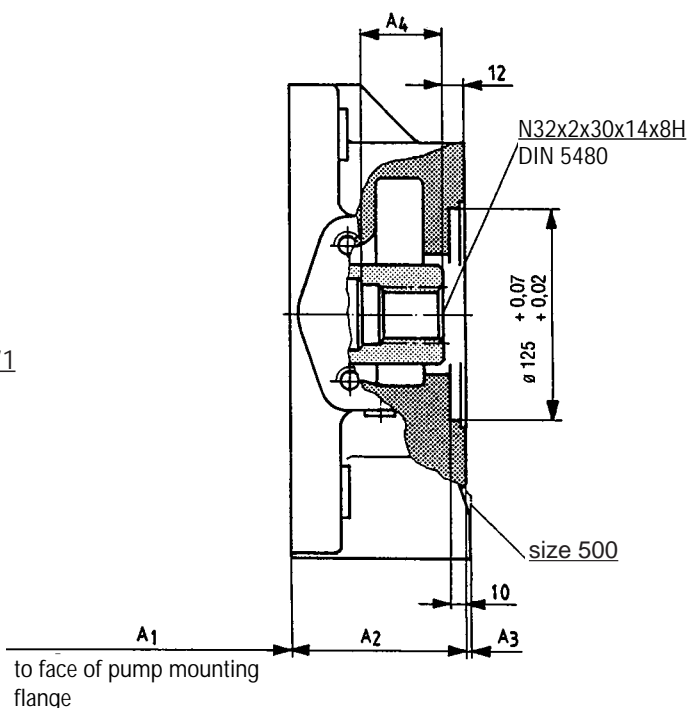
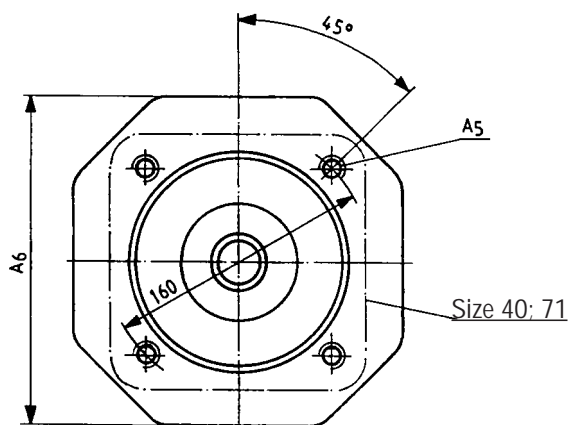

Size Main pump	A <sub>1</sub>	A <sub>2</sub>	A <sub>3</sub>	A <sub>4</sub>	A <sub>5</sub>	A <sub>6</sub>
40	189	99	–	58	M12; 24 deep	–
71	216	100	–	55	M12; 24 deep	–
125	265	82	8	37	M12; 18 deep	150
180	265	106	–	37	M12; 18 deep	160
250	327	104	2	48	M12; 18 deep	200
355	327	133	–	48	M12; 18 deep	220
500	365	140	14	60	M12; 18 deep	240

**ISO 140, 4-hole;** for mounting an A4VSO/H/G 71 (splined shaft)  
Ordering code **K33**

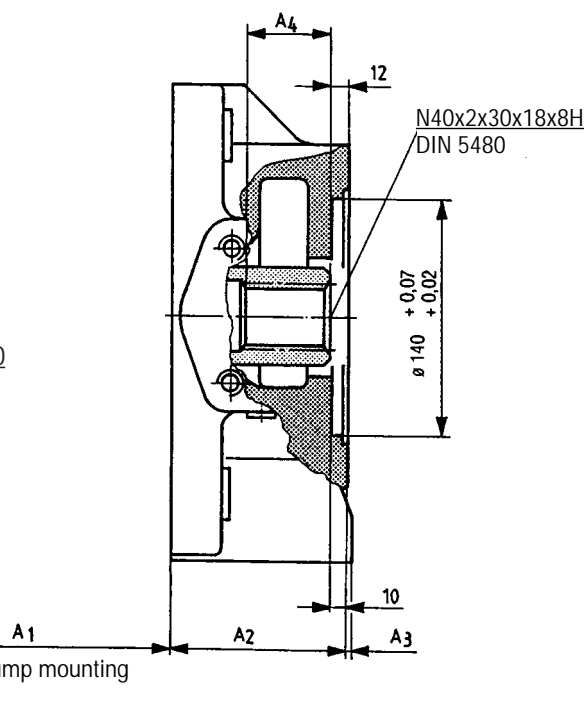
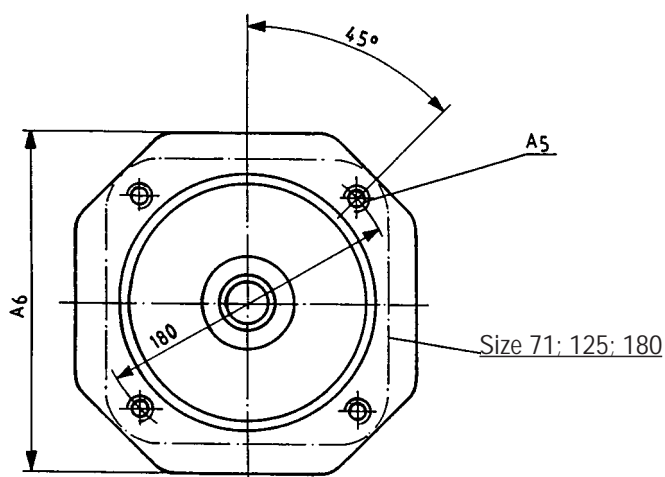

Size Main pump	A <sub>1</sub>	A <sub>2</sub>	A <sub>3</sub>	A <sub>4</sub>	A <sub>5</sub>	A <sub>6</sub>
71	216	100	–	44	M12; 24 deep	–
125	265	108	–	45	M12; 25 deep	–
180	265	132	–	45	M12; 18 deep	–
250	327	104	2	48	M12; 18 deep	200
355	327	133	–	48	M12; 18 deep	220
500	365	140	15	60	M12; 18 deep	240

**ISO 160, 4-hole;** for mounting an A4VSO/H/G 125 or 180 (splined shaft)  
Ordering code **K34**

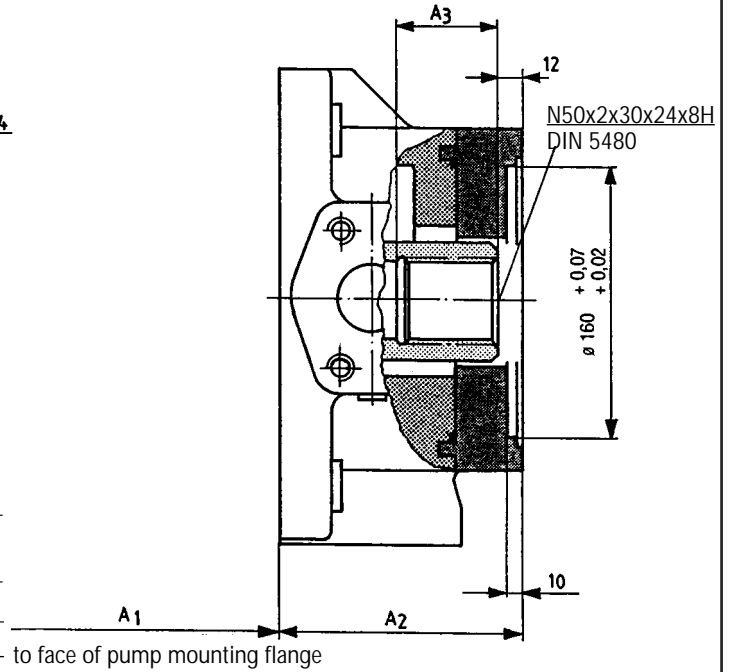
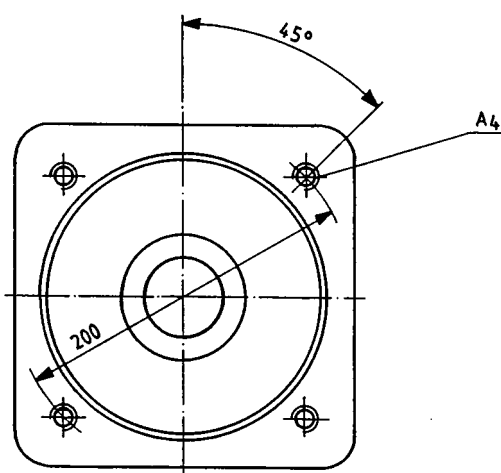

Size	A <sub>1</sub>	A <sub>2</sub>	A <sub>3</sub>	A <sub>4</sub>
Main pump				
125	265	114	58	M16; 31 deep
180	265	138	53	M16; 32 deep
250	327	142	60	M16; 32 deep
355	327	171	60	M16; 32 deep
500	365	140	60	M16; 24 deep

**ISO 224, 4-hole;** for mounting an A4VSO/H/G 250 (splined shaft)  
Ordering code **K35**

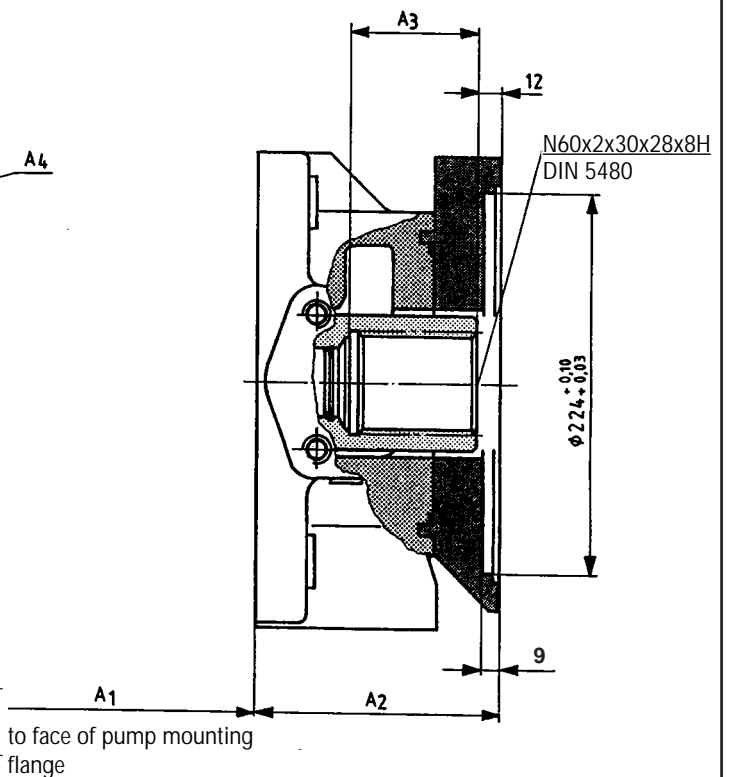
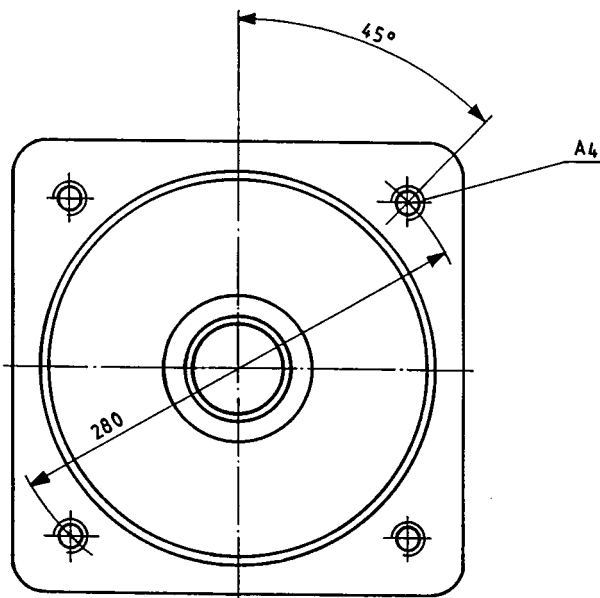

Size	A <sub>1</sub>	A <sub>2</sub>	A <sub>3</sub>	A <sub>4</sub>
Main pump				
250	327	142	75	M20; 37 deep
355	327	171	75	M20
500	365	176	74	M20; 36 deep

**ISO 224, 4-hole;** for mounting an A4VSO/G 355 (splined shaft)  
Ordering code **K77**

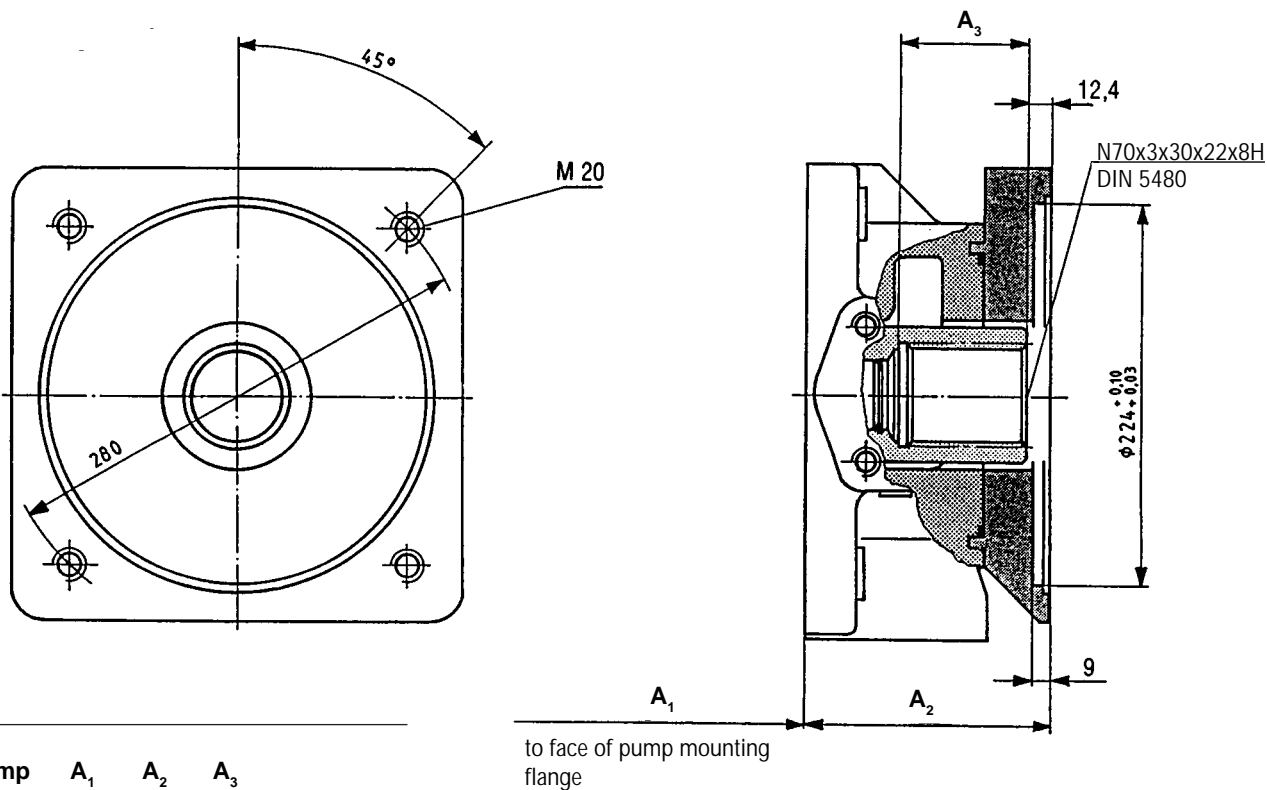

Size			
Main pump	A <sub>1</sub>	A <sub>2</sub>	A <sub>3</sub>
355	327	171	82
500	365	176	76

**ISO 315, 8-hole;** for mounting an A4VSO/G 500 (spline shaft)  
Ordering code **K43**

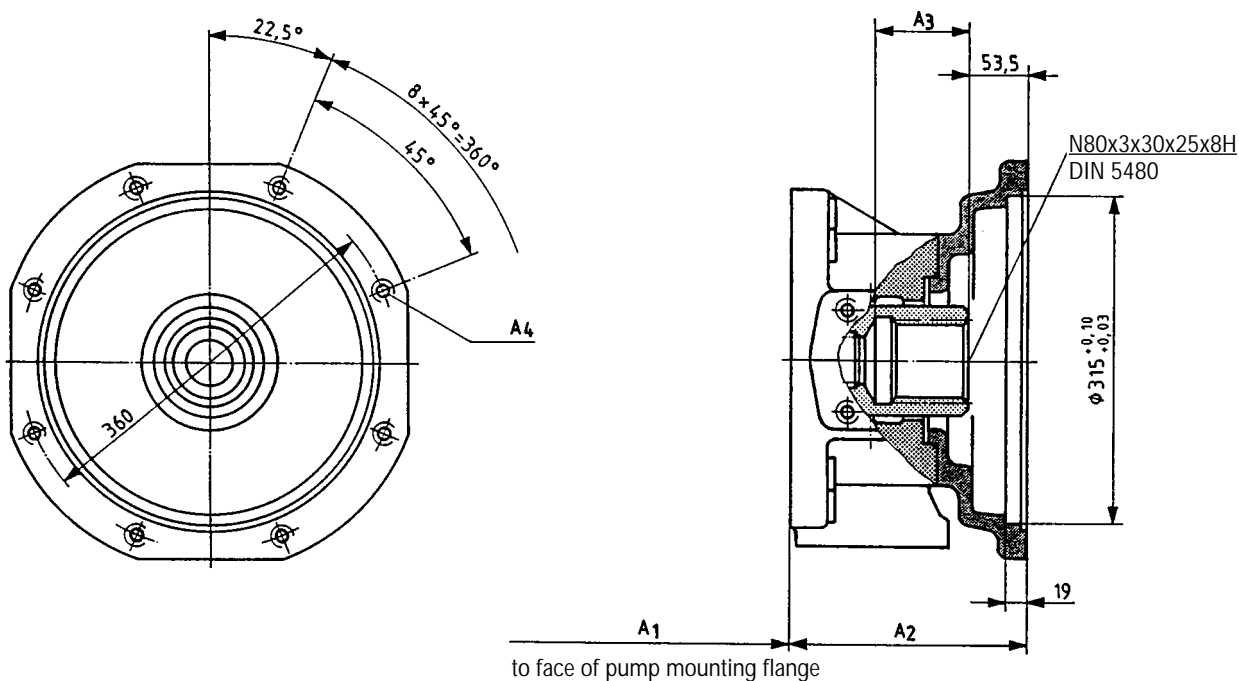

Size				
Main pump	A <sub>1</sub>	A <sub>2</sub>	A <sub>3</sub>	A <sub>4</sub>
500	365	225	91	M20; 26 deep
750	397	243	91	M20; 26 deep

**ISO 400, 8-hole;** for mounting a second A4VSO/G 750 (splined shaft)  
Ordering code **K76**  
Main pump nominal size 750

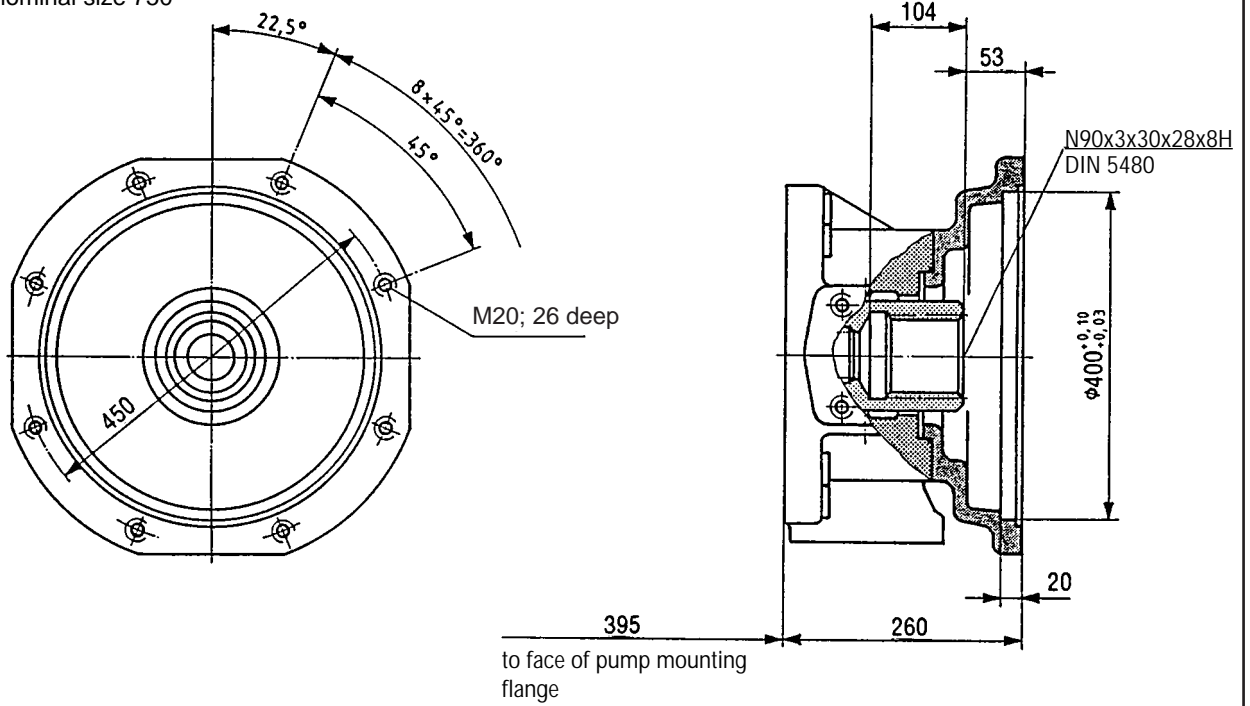

**ISO 400, 8-hole;** for mounting a second A4VSO/G 1000 (splined shaft)  
Ordering code **K88**  
Main pump nominal size 1000

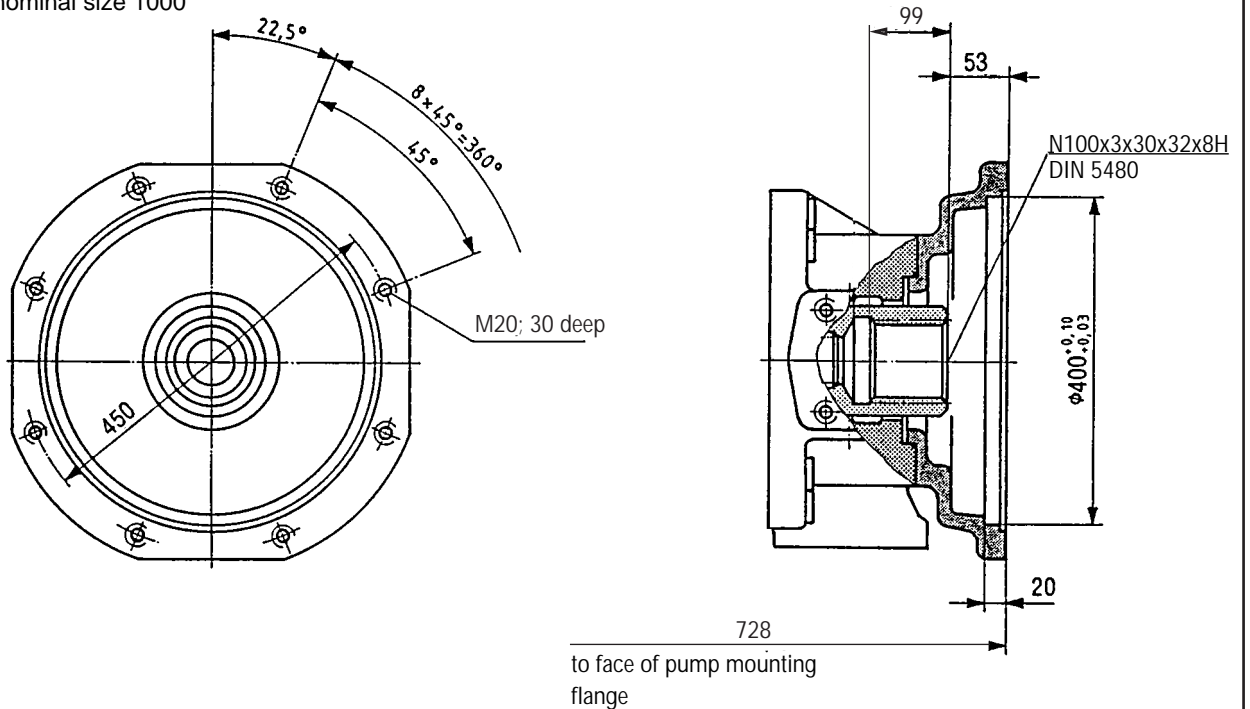

**ISO 80, 2-hole;** for mounting an A10VSO 18 (splined shaft S) - see RE 92712  
Ordering code **KB2**

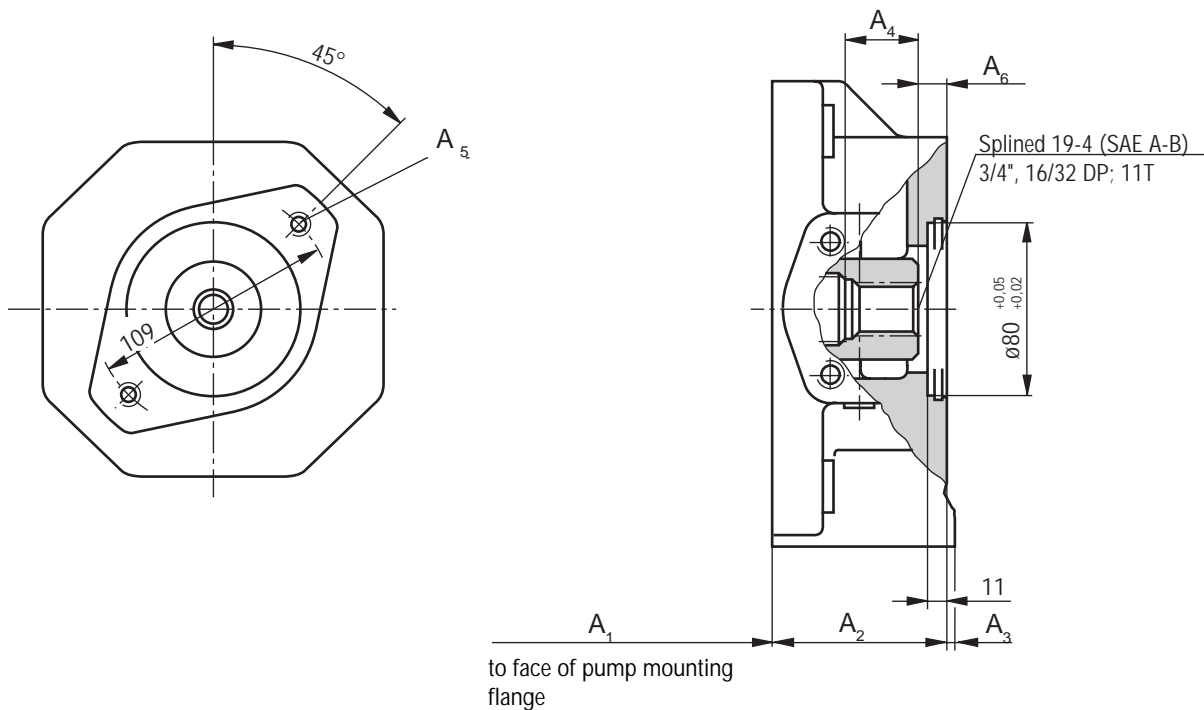

Size						
Main pump	A <sub>1</sub>	A <sub>2</sub>	A <sub>3</sub>	A <sub>4</sub>	A <sub>5</sub>	A <sub>6</sub>
125	265	82	11.5	19.1	M10	21.4

**ISO 100, 2-hole;** for mounting an A10VSO 28 (splined shaft S) - see RE 92711 (in preparation)  
Ordering code **KB3**

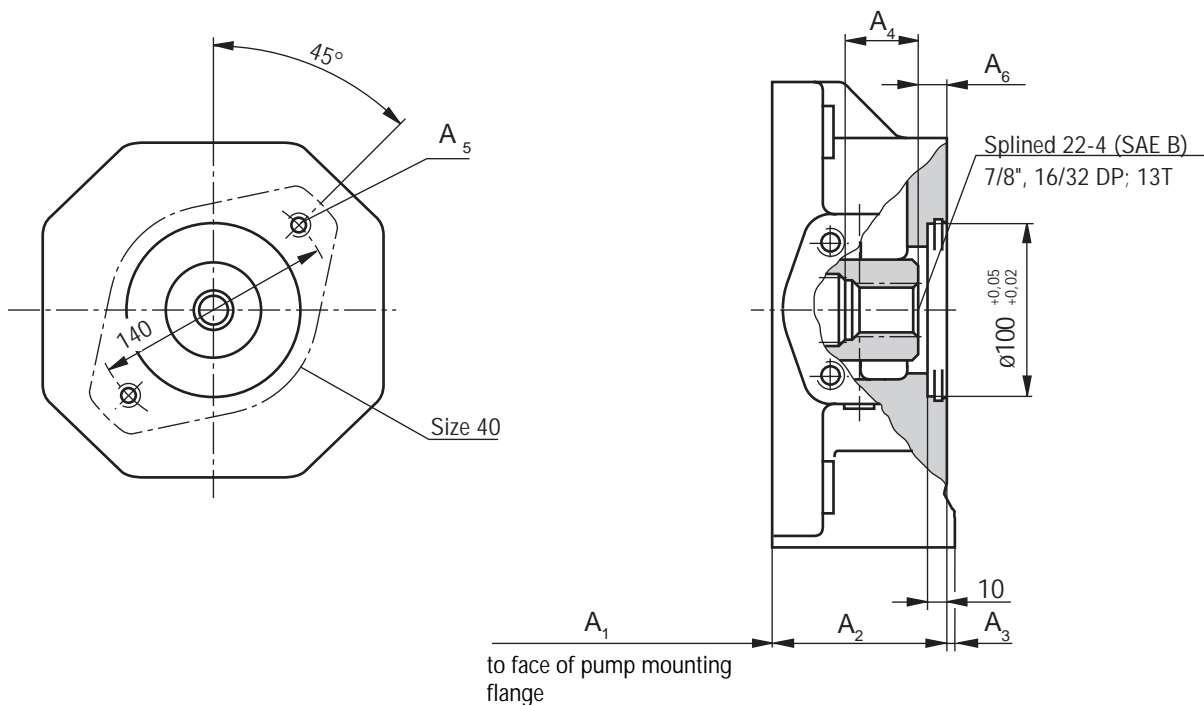

Size						
Main pump	A <sub>1</sub>	A <sub>2</sub>	A <sub>3</sub>	A <sub>4</sub>	A <sub>5</sub>	A <sub>6</sub>
40	189	101	-	55	M12; 26 deep	20.3

**ISO 100, 2-hole;** for mounting an A10VSO 45 (splined shaft S) - see RE 92711 (in preparation)  
Ordering code **KB4**

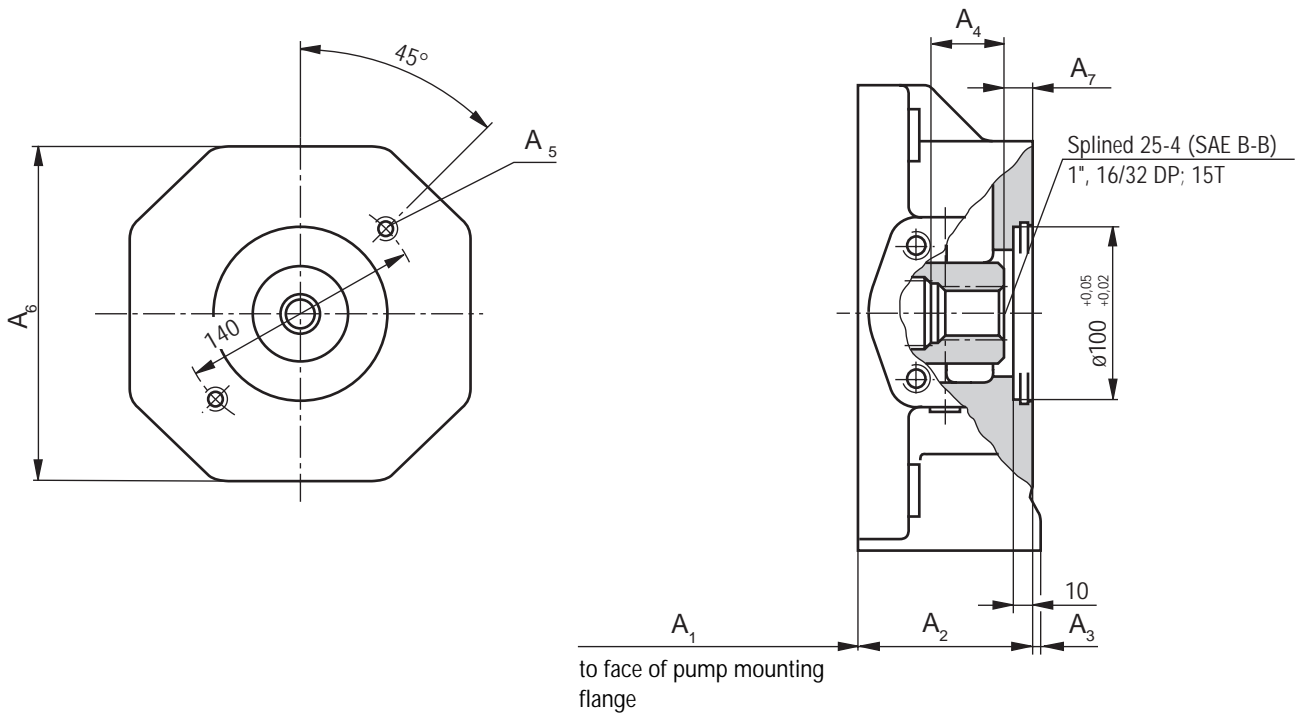

Size							
Main pump	A <sub>1</sub>	A <sub>2</sub>	A <sub>3</sub>	A <sub>4</sub>	A <sub>5</sub>	A <sub>6</sub>	A <sub>7</sub>
250	327	104	3	27.5	M12; 18 deep	200	20.9

**ISO 125, 2-hole;** for mounting an A10VSO 71 (splined shaft S) - see RE 92711 (in preparation)  
Ordering code **KB5**

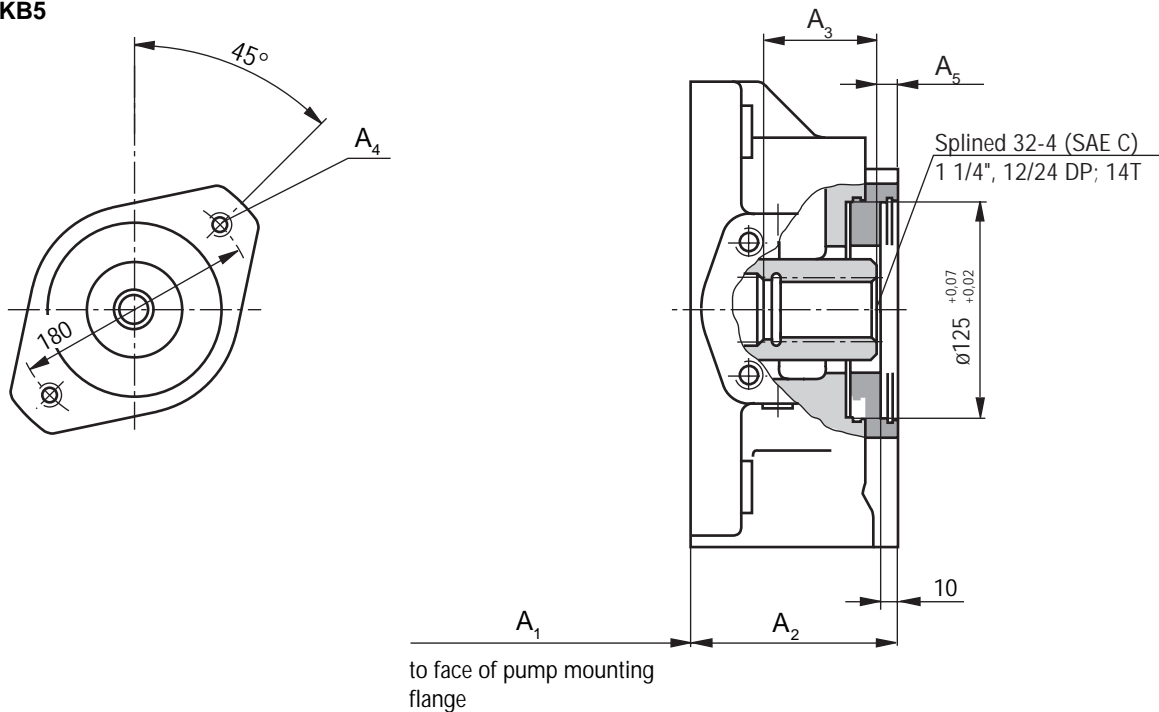

Size					
Main pump	A <sub>1</sub>	A <sub>2</sub>	A <sub>3</sub>	A <sub>4</sub>	A <sub>5</sub>
125	265	113	38.1	M16; 24 deep	23.7
180	265	137	38.1	M16; 24 deep	23.7



**ISO 180, 4-hole;** for mounting an A10VSO 140 (splined shaft S) - see RE 92711 (in preparation)

Ordering code **KB7**

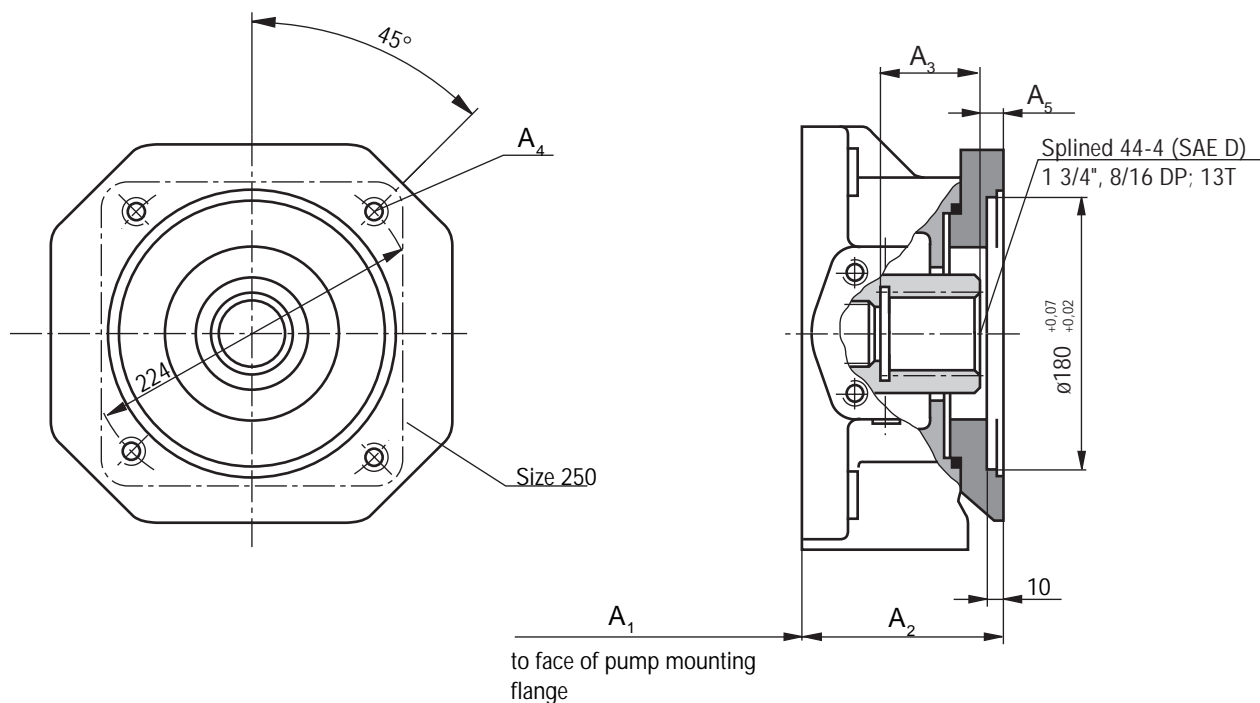

Size Main pump	A <sub>1</sub>	A <sub>2</sub>	A <sub>3</sub>	A <sub>4</sub>	A <sub>5</sub>
250	327	142	82	M16; 32 deep 10.8	
355	327	171	82	M16; 32 deep 10.8	

**Flange SAE 82-2 (SAE A, 2-hole);** for mounting an external gear pump G2 (see RE 10030) or, of an internal gear pump 1 PF2GC2/3-1X/XXXXR07MU2 (see RE 10215)

Ordering code **K01**

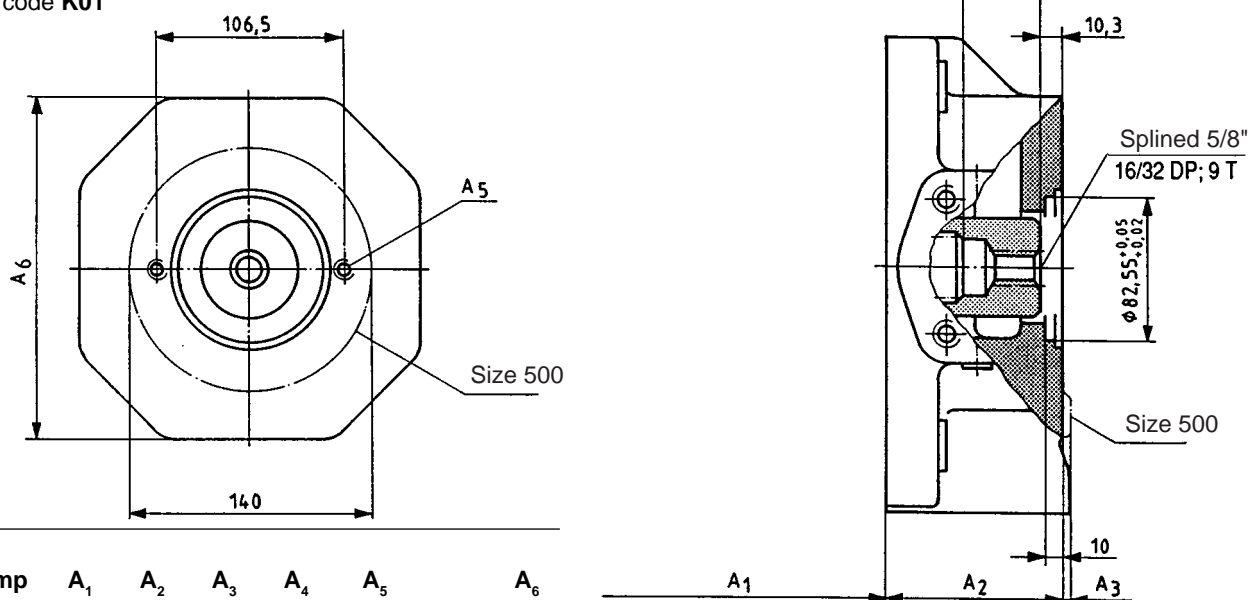

Size Main pump	A <sub>1</sub>	A <sub>2</sub>	A <sub>3</sub>	A <sub>4</sub>	A <sub>5</sub>	A <sub>6</sub>
40	189	74	-	40	M10; 15 deep 130	
71	216	75	2	37	M10; 15 deep 140	
125	265	82	8	39	M10; 20 deep 150	
180	265	106	-	28	M10; 15 deep -	
250	327	104	3	50	M10; 15 deep 200	
355	327	133	-	50	M10; 15 deep 220	
500	365	140	12	62	M10; 15 deep -	
750	365	190	-	62	M10; 15 deep -	

to face of pump mounting flange

**For hydraulic fluid please refer to RE 10030 or 10215.**

**Flange SAE 82-2 (SAE A, 2-hole);** for mounting an A10VSO 18 shaft S (see RE 92712)

Ordering code **K52**

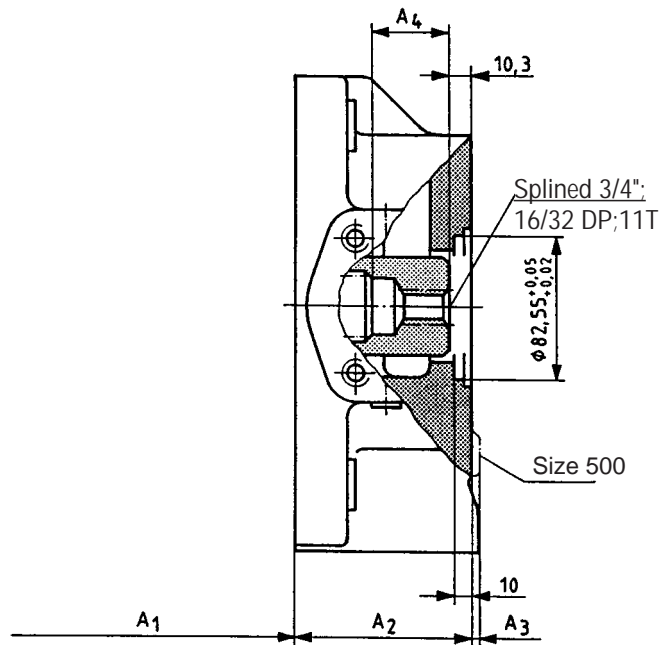
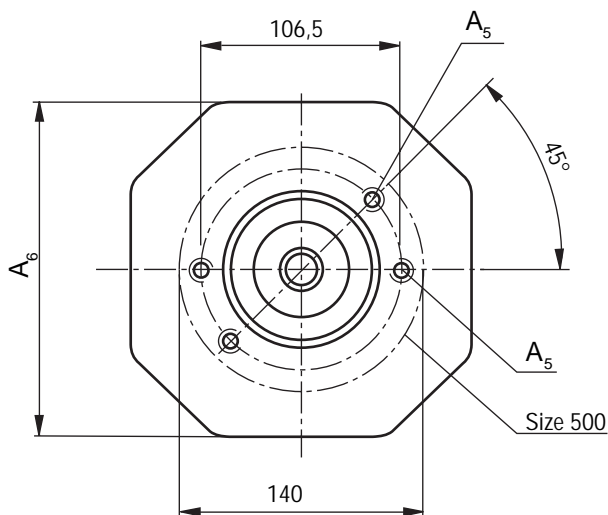

Size Main pump	A <sub>1</sub>	A <sub>2</sub>	A <sub>3</sub>	A <sub>4</sub>	A <sub>5</sub>	A <sub>6</sub>
40	189	74	–	40	M10; 15 deep	130
71	216	75	2	37	M10; 15 deep	140
125	265	82	8	39	M10; 20 deep	150
250	327	104	3	50	M10; 15 deep	200
180	265	106	–	28	M10; 15 deep	–
355	327	133	–	50	M10; 15 deep	220
500	365	140	12	62	M10; 15 deep	–

to face of pump mounting flange

**Flange SAE 101-2 (SAE B, 2-hole);** for mounting an external gear pump G3 (see RE 10039)

Ordering code **K02**

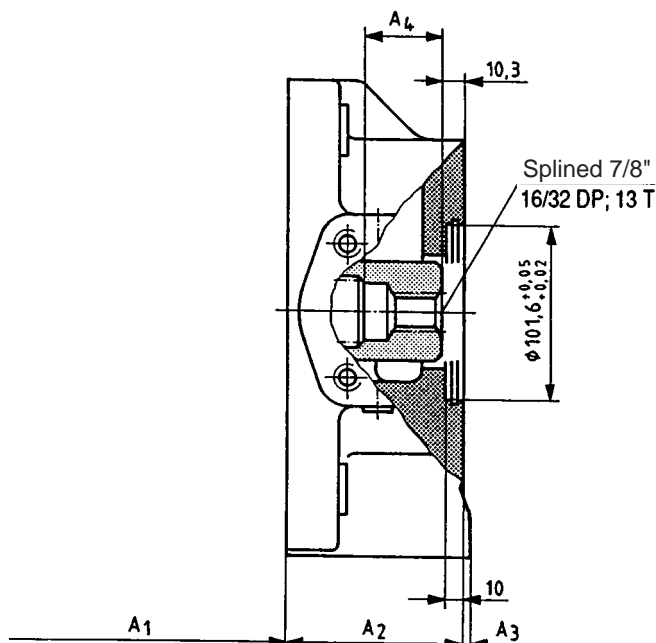
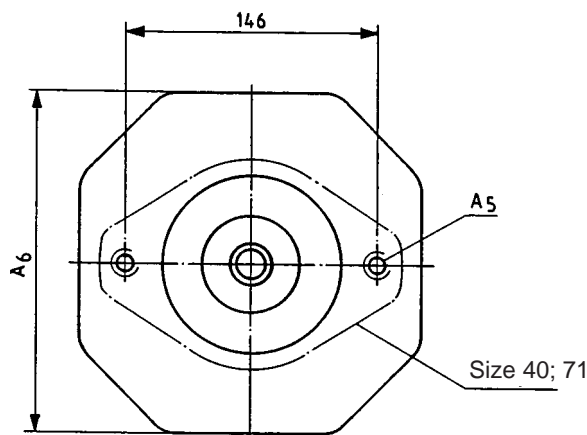

Size Main pump	A <sub>1</sub>	A <sub>2</sub>	A <sub>3</sub>	A <sub>4</sub>	A <sub>5</sub>	A <sub>6</sub>
40	189	101	–	64	M12; 26 deep	–
71	216	106	–	64	M12; 30 deep	–
125	265	82	8	39	M12; 15 deep	150
180	265	106	–	39	M12; 15 deep	160
250	327	104	3	50	M12; 18 deep	200
355	327	133	–	50	M12; 18 deep	220
500	365	140	–	62	M12; 18 deep	240

to face of pump mounting flange

When mounting a G3 as 2nd pump please refer to RE 10039 for hydraulic fluid.

**Flange SAE 101-2 (SAE B, 2-hole)** for mounting an A10VO 45 shaft S (see RE 92701) or a gear pump 1PF2GC4-1X/0XXXR07MU2 (see RE 10215),  
Ordering code **K04**

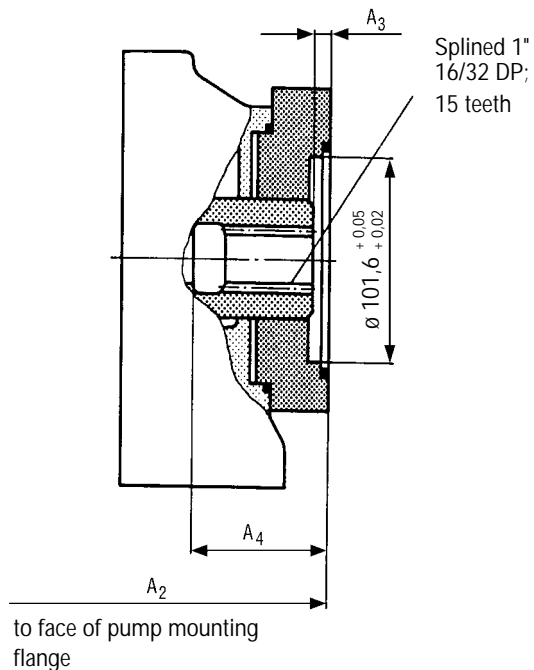
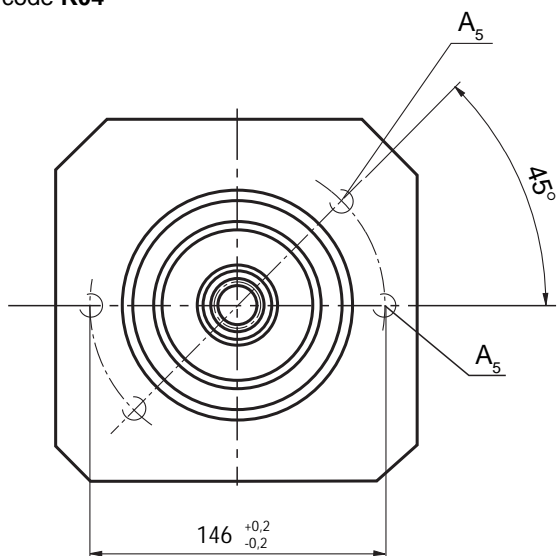

Size Main pump	A <sub>2</sub>	A <sub>3</sub>	A <sub>4</sub>	A <sub>5</sub>
125	347	9	48.4	M12; 15 deep
250	431	10.4	61	M12; 18 deep
355	460	10.4	52.4	M12; 18 deep

For hydraulic fluid please refer to RE data sheet for second pump.

**Flange SAE 101-2 (SAE B, 2-hole)** for mounting an internal gear pump 1PF2GC5-1X/0XXXR07MU2 (see RE 10215),  
Ordering code **K06**

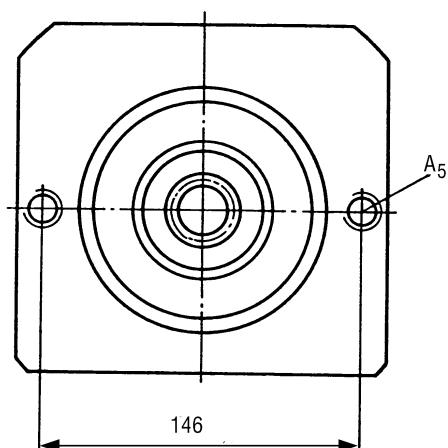

to face of pump mounting flange

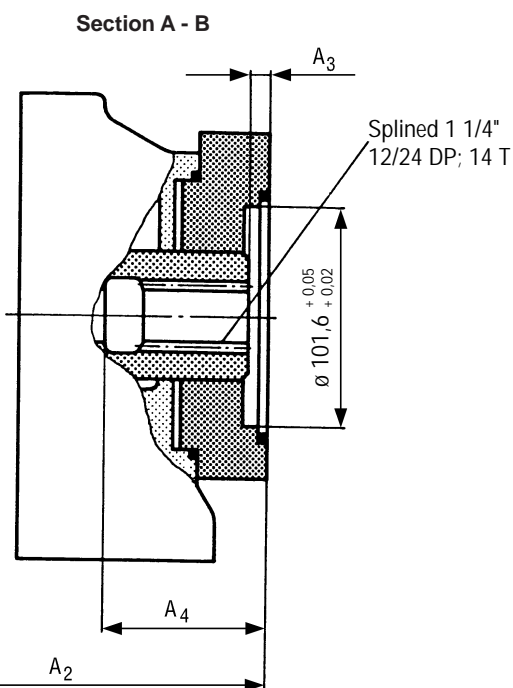

Size Main pump	A <sub>2</sub>	A <sub>3</sub>	A <sub>4</sub>	A <sub>5</sub>
71	321	10.5	59.5	M12;
125	378	9	56.6	M12; 18 deep

For hydraulic fluid please refer to RE data sheet for second pump.

**Flange SAE 127-2 (SAE C, 2-hole)** for mounting an A10VO 100 shaft S (see RE 92701) or an internal gear pump 1PF2GC6-1X/XXXXR07MU2 (see RE 10215)  
Ordering code **K24**

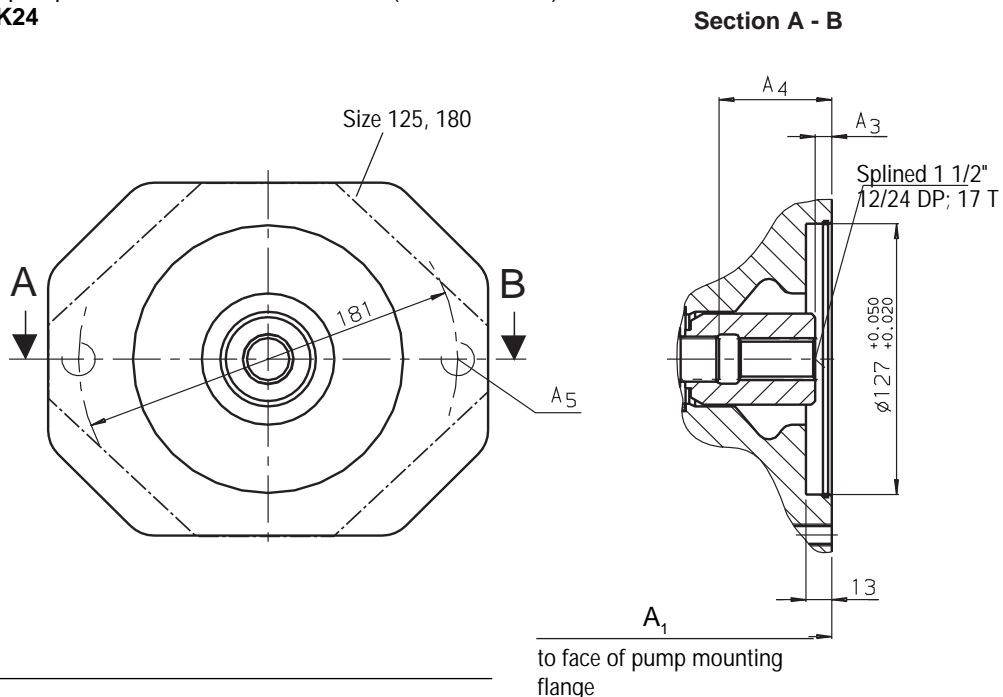

Size Main pump	A <sub>1</sub>	A <sub>3</sub>	A <sub>4</sub>	A <sub>5</sub>
125	377	9	74	M16; 24 deep
180	401	10	72	M16; 24 deep
250	451	10.5	76	M16; 20 deep

**Ø 63 metric, 4-hole;** for mounting a radial piston pump R4 (see RE 11263), Ordering code **K57**

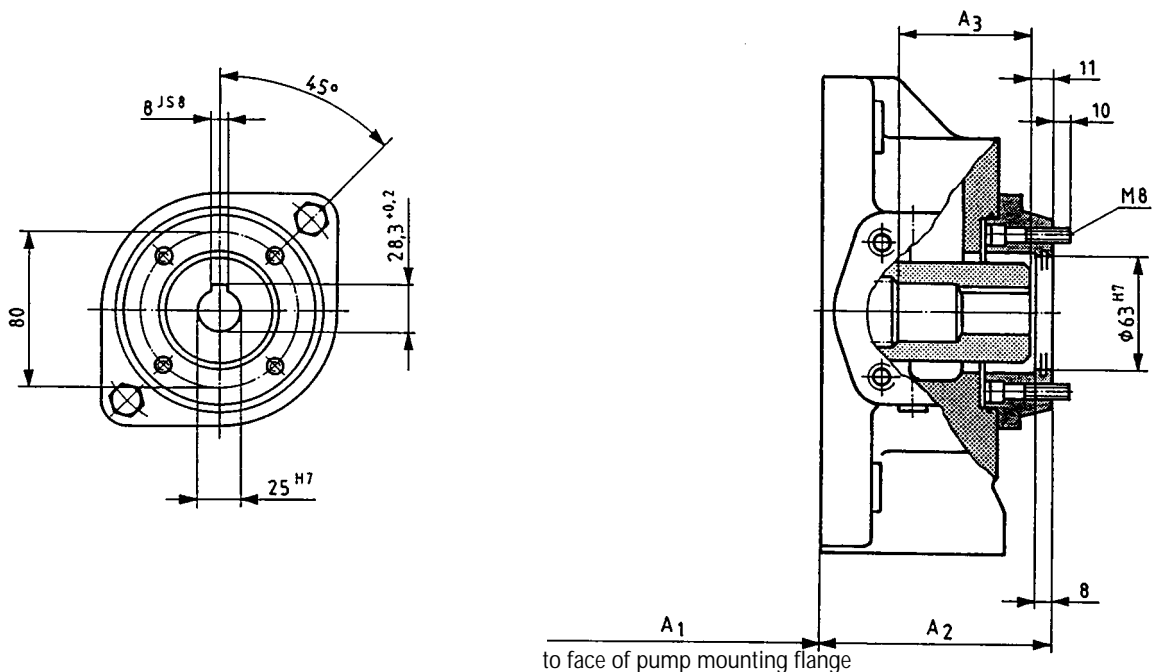

Size Main pump	A <sub>1</sub>	A <sub>2</sub>	A <sub>3</sub>
40*	189	100	61
71*	216	103	56
125	265	110	62
250	327	132	78

**For hydraulic fluid please refer to RE data sheet of 2nd pump.**

\* with A4VSO 40 and 71 LR.D, LR.S, LR.G only a R4-3 piston pump is possible

**Flange SAE 101-2 (SAE B, 2-hole);** for mounting an external gear pump G4 (see RE 10042) or an A10VO 28 splined shaft S (see RE 92701),  
Ordering code **K68**

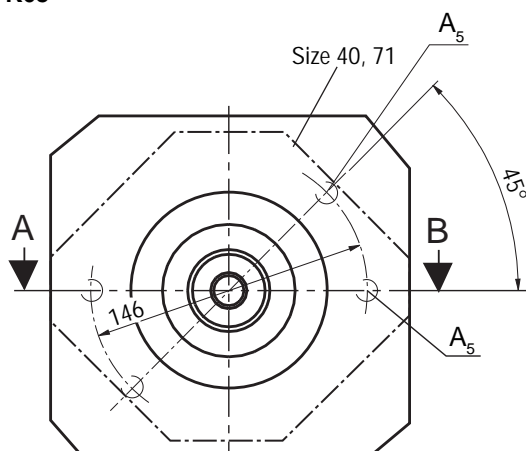

Section A - B

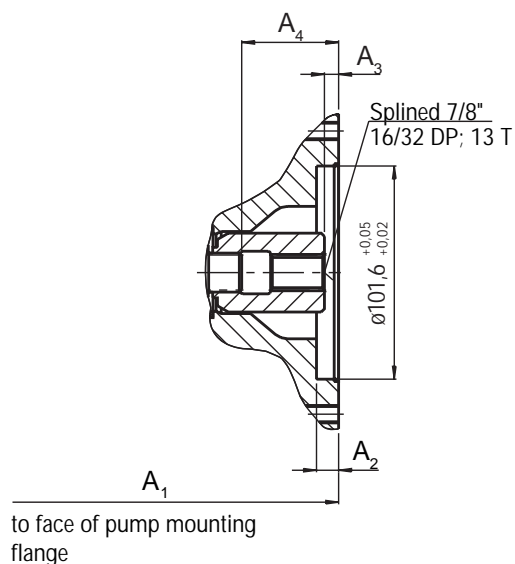

Size Main pump	A <sub>1</sub>	A <sub>2</sub>	A <sub>3</sub>	A <sub>4</sub>	A <sub>5</sub>
40	290	10.3	10	47	M12
71	322	10.3	10	62	M12
125	355	10	9	49	M12; 15 deep
180	371	10.3	10	49	M12; 18 deep
250	431	11	10	47	M12; 26 deep
500	505	10.3	10	78	M12

When mounting a G4 pump please take the hydraulic fluid into account.

**With through drive shaft, without hub or adapter flange, closed with cover plate**

Ordering code **K99**

**Nominal sizes 40 - 355**

(nominal size 500 see page 39)

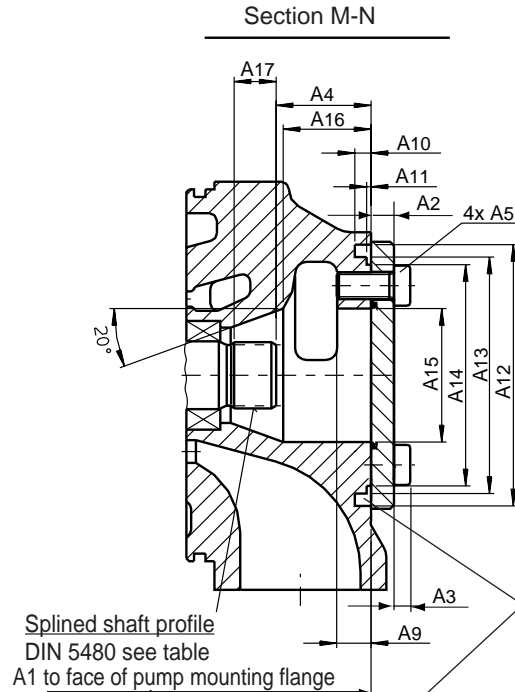
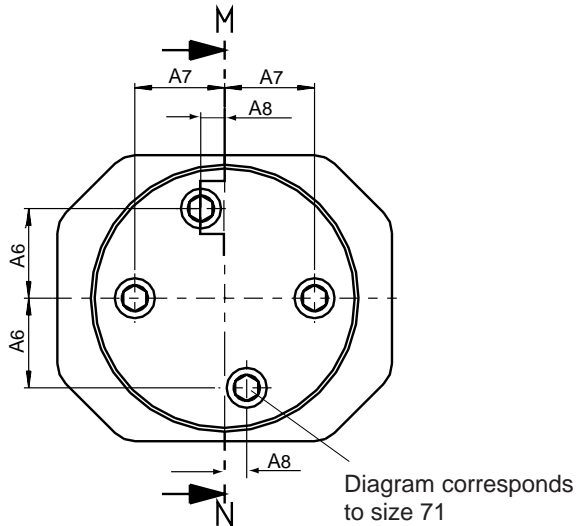

Size Main pump	Splined shaft profile DIN 5480
40	W 25 x 1,25 x 30 x 18 x 9 g
71	W 30 x 1,25 x 30 x 22 x 9 g
125	W 35 x 1,25 x 30 x 26 x 9 g
180	W 35 x 1,25 x 30 x 26 x 9 g
250	W 42 x 1,25 x 30 x 32 x 9 g
355	W 42 x 1,25 x 30 x 32 x 9 g

Size Main pump	O-ring (not included within the scope of supply)
40	99x3 78 SH A
71	PRP 245 7509
125	119x3 78 SH A
180	119x3 78 SH A
250	162x3 78 SH A
355	162x3 78 SH A

Size Main pump	A <sub>1</sub>	A <sub>2</sub>	A <sub>3</sub>	A <sub>4</sub>	A <sub>5</sub>	A <sub>6</sub>	A <sub>7</sub>	A <sub>8</sub>	A <sub>9</sub>	A <sub>10</sub>	A <sub>11</sub>	A <sub>12</sub>	A <sub>13</sub>	A <sub>14</sub>	A <sub>15</sub>	A <sub>16</sub>	A <sub>17</sub>
40	263	10	7,5	51,3 <sub>±1</sub>	M12x25	37 <sub>±0,2</sub>	37 <sub>±0,2</sub>	0	18	9	2,3 <sub>+0,1</sub>	∅118	∅105 <sub>g6</sub>	∅97,6 <sub>-0,4</sub>	∅52	44	14
71	291	10	7,5	48 <sub>±1</sub>	M12x25	42,3	45 <sub>±0,15</sub>	15,4 <sub>±0,15</sub>	18	9	2,7 <sub>+0,1</sub>	∅130	∅116 <sub>g6</sub>	∅106,4 <sub>-0,4</sub>	∅63	38	16
125	347	12	8,5	49,7 <sub>±1</sub>	M14x30	47 <sub>±0,15</sub>	47 <sub>±0,15</sub>	0	18	8,5	2,3 <sub>+0,1</sub>	∅137	∅124 <sub>g6</sub>	∅116 <sub>-0,4</sub>	∅70	46	22
180	371	12	8,5	49,7 <sub>±1</sub>	M14x30	47 <sub>±0,15</sub>	47 <sub>±0,15</sub>	0	18	8,5	2,3 <sub>+0,1</sub>	∅137	∅124 <sub>g6</sub>	∅116 <sub>-0,4</sub>	∅70	46	25
250	431	15	12	61,4 <sub>±1</sub>	M20x40	63 <sub>±0,15</sub>	63 <sub>±0,15</sub>	0	26	9	2,3 <sub>+0,1</sub>	∅180	∅165 <sub>g6</sub>	∅157 <sub>-0,4</sub>	∅88	64	30,5
355	460	15	12	61,4 <sub>±1</sub>	M20x40	63 <sub>±0,15</sub>	63 <sub>±0,15</sub>	0	26	9	2,3 <sub>+0,1</sub>	∅180	∅165 <sub>g6</sub>	∅157 <sub>-0,4</sub>	∅88	64	34

**With through drive shaft, without hub or adapter flange, closed with cover plate**Ordering code **K99**Nominal size **500**

Shown without cover

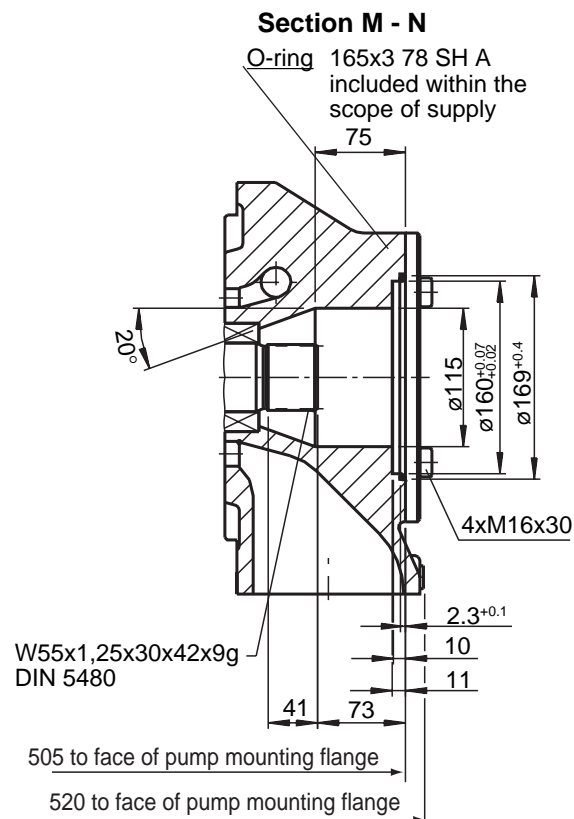
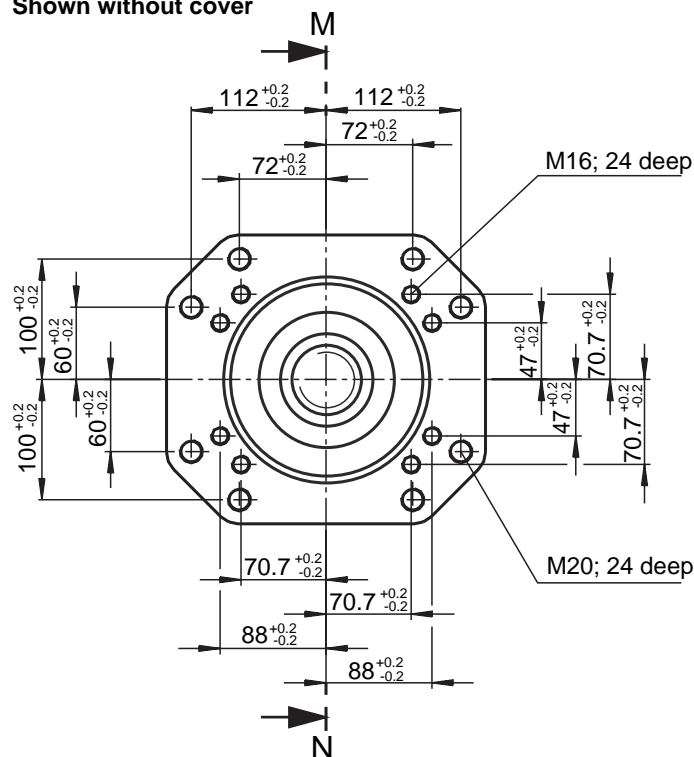
**Type list (short delivery times)**, in case of an order please state type and part no.

Type	Ident. no.	Type	Ident. no.
A4VSO40DFR/10X-PPB13N00	902310	A4VSO180DFR/22R-PPB13N00	934730
A4VSO40DR/10X-PPB13N00	955019	A4VSO180DR/22R-PPB13N00	934611
A4VSO40DRG/10X-PPB13N00	901396	A4VSO180DRG/22R-PPB13N00	949541
A4VSO40LR2/10R-PPB13N00	903578	A4VSO180LR2/22R-PPB13N00	939769
A4VSO40LR2G/10R-PPB13N00	905023	A4VSO180LR2G/22R-PPB13N00	935375
		A4VSO180LR2N/22R-PPB13N00	934974
A4VSO71DFR/10X-PPB13N00	931535	A4VSO250DFR/30R-PPB13N00	985509
A4VSO71DR/10X-PPB13N00	933007	A4VSO250DR/30R-PPB13N00	974769
A4VSO71DRG/10X-PPB13N00	942715	A4VSO250DRG/30R-PPB13N00	976965
A4VSO71LR2/10R-PPB13N00	904555	A4VSO250LR2/30R-PPB13N00	985297
A4VSO71LR2D/10R-PPB13N00	905142	A4VSO250LR2G/30R-PPB13N00	977295
		A4VSO250LR2N/30R-PPB13N00	978355
A4VSO125DFR/22R-PPB13N00	939924		
A4VSO125DR/22R-PPB13N00	937693		
A4VSO125DR/22R-VPB13N00	938745		
A4VSO125LR2/22R-PPB13N00	936376		
A4VSO125LR2G/22R-PPB13N00	940247		
A4VSO125LR2N/22R-PPB13N00	940251		

Variable displacement pump A4VSO, series 1, 2 and 3

Brueninghaus Hydromatik GmbH, Werk Horb, An den Kelterwiesen 14, D-72160 Horb, Tel. (07451) 920, Telex 765 321, Telefax (07451) 8221